

**FS-2000D  
FS-3900DN  
FS-4000DN**

# **Advanced Operation Guide**

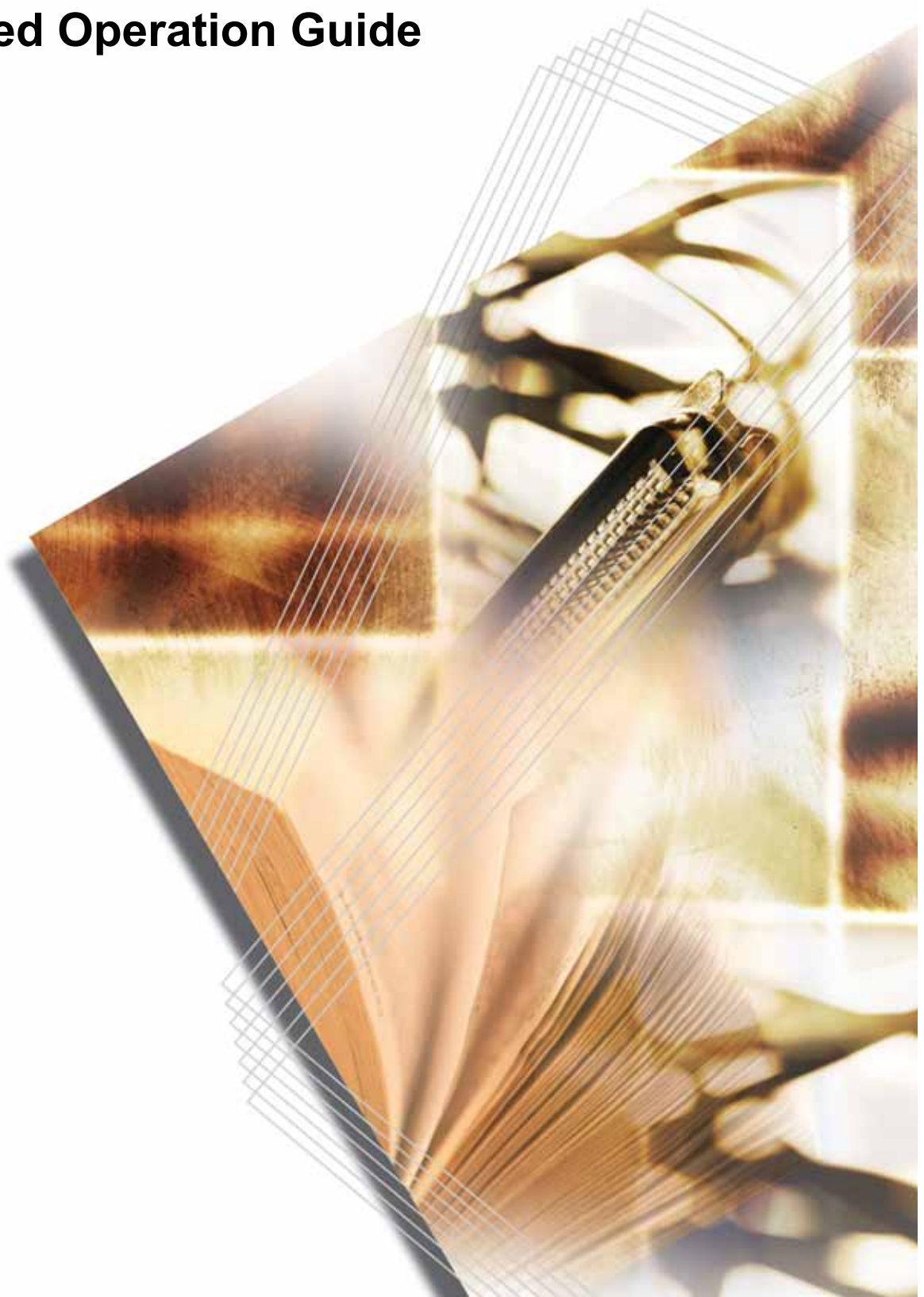



# Contents

<b>1</b>	<b>Handling Paper</b>	
	General Guidelines .....	1-2
	Selecting the Right Paper .....	1-4
	Paper Type .....	1-12
	Loading Paper .....	1-13
<b>2</b>	<b>Using the Operation Panel</b>	
	General Information .....	2-2
	Understanding the Operation Panel .....	2-3
	Canceling a Printing Job .....	2-10
	Using the Menu Selection System .....	2-11
	Status Pages .....	2-15
	e-MPS .....	2-19
	Changing the Interface Parameters .....	2-30
	Making Default Settings .....	2-38
	Pagination .....	2-45
	Setting Print Quality .....	2-50
	Operating the Storage Device .....	2-54
	Paper Handling .....	2-64
	Reading Life Counters .....	2-77
	Other Modes .....	2-78
<b>3</b>	<b>Options</b>	
	General Information .....	3-2
	Expansion Memory Modules .....	3-3
	General Description .....	3-6
	IB-21E/IB-30 Network Interface Cards .....	3-8
	Other Options .....	3-9
<b>4</b>	<b>Computer Interface</b>	
	General Information .....	4-2
	Parallel Interface .....	4-3
	USB Interface .....	4-5
	Serial Interface (Option) .....	4-6
	RS-232C Protocol .....	4-7
	RS-232C Cable Connection .....	4-10
	<b>Glossary</b>	
	<b>Index</b>	



# Introduction

This guide has the following chapters:

- **1 Handling Paper**  
*Explains how choose, handle and load paper.*
- **2 Using the Operation Panel**  
*Explains how to use the operation panel to configure the printer.*
- **3 Options**  
*Shows the available options.*
- **4 Computer Interface**  
*Describes the possible connections between the printer and your computer.*
- **Glossary**  
*A Glossary of terms used is provided here.*

## Conventions

This manual uses the following conventions:

Convention	Description	Example
<b>Italic Typeface</b>	Used to emphasize a key word, phrase or message.	Close the <i>top cover</i> . Refer to <i>Toner Container Replacement</i> on page 3-3.
<b>Courier Typeface</b>	Used to denote messages or names displayed on the operation panel.	Replace the waste toner box when the <code>Check waste toner box</code> message is displayed.
<b>Bold Typeface</b>	Used to denote operation panel keys.	Press <b>[Menu]</b> .
<b>Notes</b>	Used to provide additional or useful information about a function or feature.	<b>NOTE:</b> For information about storing the pin, refer to step 10.
<b>Important</b>	Use to provide important information.	<b>IMPORTANT:</b> Ensure paper is not folded, curled, or damaged.
<b>Caution</b>	Cautions are statements that suggest <i>mechanical</i> damage as a result of an action.	<b>CAUTION:</b> Do not pull the cassette out when holding the front of the machine.
<b>Warning</b>	Used to alert users to the possibility of <i>personal</i> injury.	<b>WARNING:</b> High voltage is present in the charger section.

# 1 Handling Paper

This chapter contains explanations on the following topics:

- General Guidelines..... 1-2
- Selecting the Right Paper..... 1-4
- Paper Type ..... 1-12
- Loading Paper ..... 1-13

## General Guidelines

The machine is designed to print on standard copier paper (the type used in ordinary dry copier machines), but it can also accept a variety of other types of paper within the limits specified below.

---

**NOTE:** The manufacturer assumes no liability for problems that occur when paper not satisfying these requirements is used.

---

Selection of the right paper is important. Using the wrong paper can result in paper jams, curling, poor print quality, and paper waste, and in extreme cases can damage the machine. The guidelines given below will increase the productivity of your office by ensuring efficient, trouble-free printing and reducing wear and tear on the machine.

### Paper Availability

Most types of paper are compatible with a variety of machines. Paper intended for xerographic copiers can also be used with the machine.

There are three general grades of paper: *economy*, *standard*, and *premium*. The most significant difference between grades is the ease with which they pass through the machine. This is affected by the *smoothness*, *size*, and *moisture content* of the paper, and the way in which the paper is cut. The higher the grade of paper you use, the less risk there will be of paper jams and other problems, and the higher the level of quality your printed output will reflect.

Differences between paper from different suppliers can also affect the machine's performance. A high-quality printer cannot produce high-quality results when the wrong paper is used. Low-priced paper is not economical in the long run if it causes printing problems.

Paper in each grade is available in a range of basis weights (defined later). The traditional standard weights are 60 to 120 g/m<sup>2</sup> (16 to 28 pounds).

### Paper Specifications

The following table summarizes the basic paper specifications. Details are given on the following pages.

Item	Specification
<b>Weight</b>	Cassette: 60 to 120g/m <sup>2</sup> MP Tray: 60 to 220g/m <sup>2</sup>
<b>Thickness</b>	0.086 to 0.110mm
<b>Dimensions</b>	Refer to <i>Paper Sizes on page 1-4</i>
<b>Dimensional accuracy</b>	±0.7mm
<b>Squareness of corners</b>	90° ±0.2°

Item	Specification
Moisture content	4% to 6%
Direction of grain	Long grain
Pulp content	80% or more

### Minimum and Maximum Paper Sizes

The minimum and maximum paper sizes are as follows. For non standard paper, the MP tray must be used.

Paper cassette

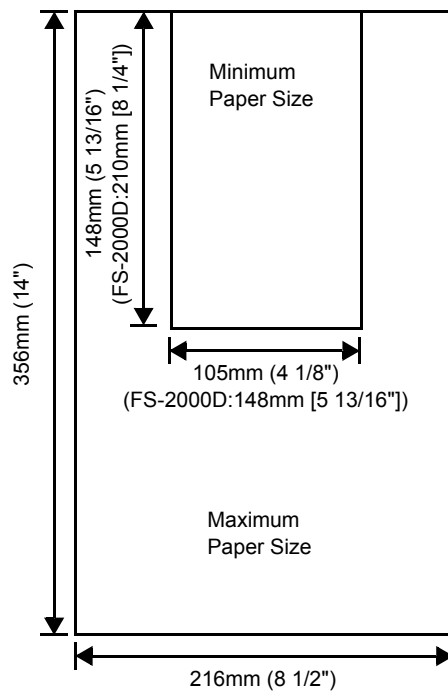

MP tray

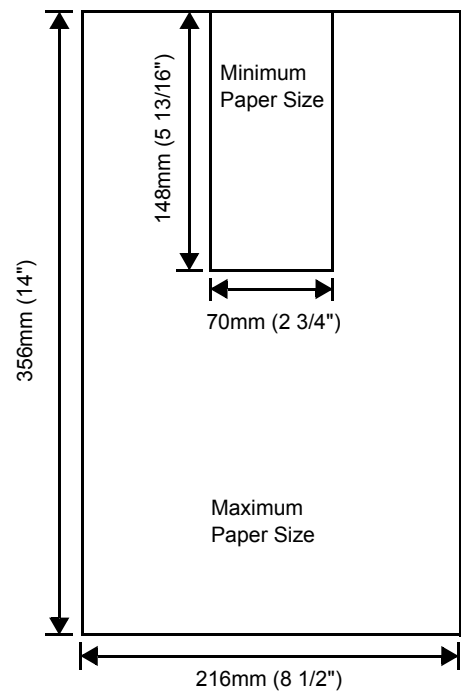

## Selecting the Right Paper

This section describes the guidelines for selecting paper.

### Condition

Avoid using paper that is bent at the edges, curled, dirty, torn, embossed, or contaminated with lint, clay, or paper shreds.

Use of paper in these conditions can lead to illegible printing and paper jams, and can shorten the life of the machine. In particular, avoid using paper with a surface coating or other surface treatment. Paper should have as smooth and even a surface as possible.

### Composition

Do not use paper that has been coated or surface-treated and contains plastic or carbon. The heat of fusing can cause such paper to give off harmful fumes.

Bond paper should contain at least 80% pulp. Not more than 20% of the total paper content should consist of cotton or other fibers.

### Paper Sizes

*Cassettes* and the *MP Tray* are available for the paper sizes listed in the table below. The dimensional tolerances are  $\pm 0.7\text{mm}$  for the length and width. The angle at the corners must be  $90^\circ \pm 0.2^\circ$ .

MP tray	Size	Cassette or MP tray	Size
Envelope Monarch	3 7/8 × 7 1/2 inches	Legal	8 1/2 × 14 inches
Envelope #10	4 1/8 × 9 1/2 inches	Letter	8 1/2 × 11 inches
ISO A6	105 × 148mm	ISO A4	210 × 297mm
Envelope DL	110 × 220mm	ISO A5	148 × 210mm
Envelope #9	3 7/8 × 8 7/8 inches	ISO A6	105 × 148mm (FS-2000D: MP tray only)
Envelope #6	3 5/8 × 6 1/2 inches	Envelope C5	162 × 229mm
JIS B6	128 × 182mm	ISO B5	176 × 250mm
Statement	5 1/2 × 8 1/2 inches	JIS B5	182 × 257mm
Hagaki	100 × 148mm	Executive	7 1/4 × 10 1/2 inches
Ofuku-Hagaki	148 × 200mm	Oficio II	8 1/2 × 13 inches
Youkei 2	114 × 162mm	Folio	210 × 330mm
Youkei 4	105 × 235mm	16 kai	197 × 273mm

MP tray	Size	Cassette or MP tray	Size
Custom	Cassette: 148 × 210 to 216 × 356mm (5 13/16 × 8 1/4 to 8 1/2 × 14 inches) MP tray: 70 × 148 to 216 × 356mm (2 3/4 × 5 13/16 to 8 1/2 × 14 inches)		

### Smoothness

The paper should have a smooth, uncoated surface. Paper with a rough or sandy surface can cause voids in the printed output. Paper that is too smooth can cause multiple feeding and fogging problems. (Fogging is a gray background effect.)

### Basis weight

Basis weight is the weight of paper expressed in grams per square meter (g/m<sup>2</sup>). Paper that is too heavy or too light may cause feed errors or paper jams as well as premature wear of the product. Uneven weight of paper, namely uneven paper thickness may cause multiple-sheet feeding or print quality problems such as blurring because of poor toner fusing.

The recommended basis weight is between 60 and 120g/m<sup>2</sup> for the cassette and between 60 and 220g/m<sup>2</sup> for the MP tray.

### Paper Weight Equivalence Table

The paper weight is listed in pounds (lb) and metric grams per square meter (g/m<sup>2</sup>). The shaded part indicates the standard weight.

U. S. Bond Weight (lb)	Europe Metric Weight (g/m <sup>2</sup> )
16	60
17	64
20	75
21	80
22	81
24	90
27	100
28	105
32	120
34	128
36	135
39	148
42	157

U. S. Bond Weight (lb)	Europe Metric Weight (g/m <sup>2</sup> )
43	163
47	176
53	199

### Thickness

The paper used with the machine should be neither extremely thick nor extremely thin. If you are having problems with paper jams, multiple feeds, and faint printing, the paper you are using may be too thin. If you are having problems with paper jams and blurred printing the paper may be too thick. The correct thickness is 0.086 to 0.110mm.

### Moisture Content

Moisture content is defined as the percent ratio of moisture to the dry mass of the paper. Moisture can affect the paper's appearance, feed ability, curl, electrostatic properties, and toner fusing characteristics.

The moisture content of the paper varies with the relative humidity in the room. When the relative humidity is high and the paper absorbs moisture, the paper edges expand, becoming wavy in appearance. When the relative humidity is low and the paper loses moisture, the edges shrink and tighten, and print contrast may suffer.

Wavy or tight edges can cause jams and alignment anomalies. The moisture content of the paper should be 4 to 6%.

To ensure correct moisture content, it is important to store the paper in a controlled environment. Some tips on moisture control are:

- Store paper in a cool, dry location.
- Keep the paper in its wrapping as long as possible. Re-wrap paper that is not in use.
- Store paper in its original carton. Place a pallet etc. under the carton to separate it from the floor.
- After removing paper from storage, let it stand in the same room as the machine for 48 hours before use.
- Avoid leaving paper where it is exposed to heat, sunlight, or damp.

### Paper Grain

When paper is manufactured, it is cut into sheets with the grain running parallel to the length (long grain) or parallel to the width (short grain). Short grain paper can cause feeding problems in the machine. All paper used in the machine should be long grain.

### Other Paper Properties

**Porosity:** Indicates the density of paper fiber.

**Stiffness:** Limp paper may buckle in the machine, resulting in paper jams.

**Curl:** Most paper naturally tends to curl one way if left unpacked. When paper passes through the fixing unit, it curls upward a little. To produce flat printouts, load the paper so that the upward pressure from the machine can correct their curling.

**Electrostatic discharge:** During the printing process the paper is electrostatically charged to attract the toner. The paper must be able to release this charge so that printed sheets do not cling together in the *Output Tray*.

**Whiteness:** The contrast of the printed page depends on the whiteness of the paper. Whiter paper provides a sharper, brighter appearance.

**Quality control:** Uneven sheet size, corners that are not square, ragged edges, welded (uncut) sheets, and crushed edges and corners can cause the machine to malfunction in various ways. A quality paper supplier should take considerable care to ensure that these problems do not occur.

**Packaging:** Paper should be packed in a sturdy carton to protect it from damage during transport. Quality paper obtained from a reputable supplier is usually correctly packaged.

## Special Paper

The following types of special paper can be used:

Paper type to be used	Paper type to be selected
Thin paper (60 to 64 g/m <sup>2</sup> )	Vellum
Thick paper (90 to 220 g/m <sup>2</sup> )	Thick
Colored paper	Color
Recycled paper	Recycled
Overhead projector transparencies	Transparency
Postcards	Cardstock
Envelopes	Envelope
Label	Labels

Use paper that is sold specifically for use with copiers or printers (heat-fusing type). When using transparencies, labels, thin paper, envelopes, postcards, or thick paper, feed the paper from the *MP Tray*.

Since the composition and quality of special paper vary considerably, special paper is more likely than white bond paper to give trouble during printing. No liability will be assumed if moisture and so forth given off during printing on special paper causes harm to the machine or operator.

---

**NOTE:** Before purchasing any type of special paper, test a sample on the machine and check that printing quality is satisfactory.

---

### Transparency

Transparencies must be able to withstand the heat of fusing during the printing process. The recommended transparency product is 3M PP2500 (Letter, A4).

Transparencies must be placed on the *MP tray* with the long edge towards the printer.

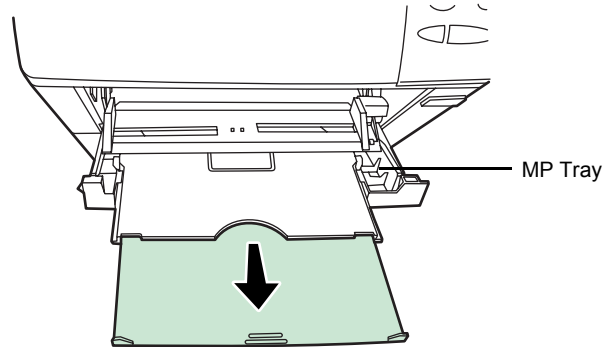

When unloading transparencies (e.g., for clearing jams), hold them carefully by the edges to avoid leaving fingerprints on them.

### Labels

Labels must be fed from the *MP Tray*.

The basic rule for printing on adhesive labels is that the adhesive must never come into contact with any part of the machine. Adhesive paper sticking to the drum or rollers will damage the machine.

Label paper has a structure comprising of three layers, as shown in the diagram. The top sheet is printed on. The adhesive layer consists of pressure-sensitive adhesives. The carrier sheet (also called the linear or backing sheet) holds the labels until used. Due to the complexity of its composition, adhesive-backed label paper is particularly likely to give printing problems.

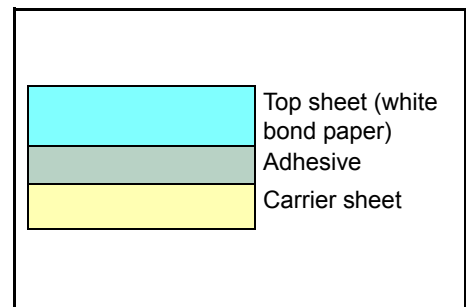

Adhesive label paper must be entirely covered by its top sheet, with no spaces between the individual labels. Labels with spaces in between are liable to peel off, causing serious paper jam problems.

Some label paper is manufactured with an extra margin of top sheet around the edge. Do not remove the extra top sheet from the carrier sheet until after printing is finished.

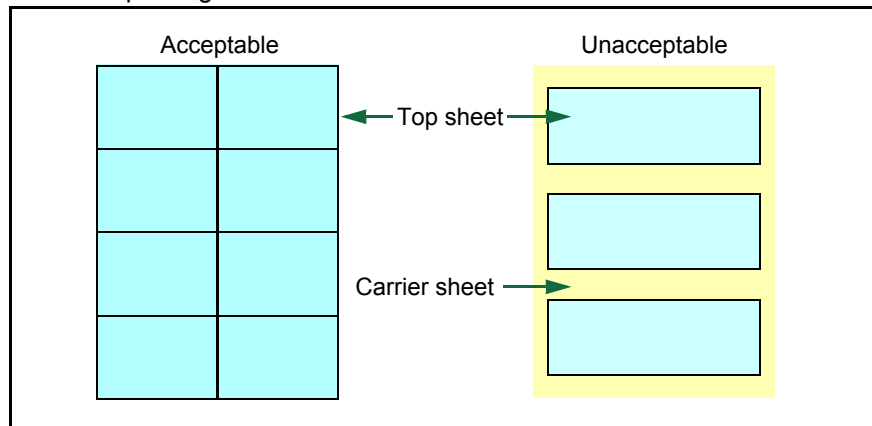

The table below lists the specifications for adhesive label paper.

Item	Specification
Weight of top sheet	44 to 74g/m <sup>2</sup>
Composite weight	104 to 151g/m <sup>2</sup>
Thickness of top sheet	0.086 to 0.107mm
Composite thickness	0.115 to 0.145mm
Moisture content	4 to 6% (composite)

### Postcards

Fan the stack of postcards and align the edges before loading them in the MP tray. Make sure the postcards you are going to set are not curled. Feeding curled postcards may cause paper jams.

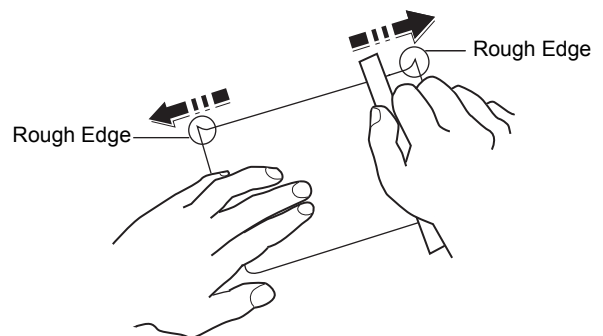

Some postcards have rough edges on the back (those are created when the paper is cut). In this case, put the postcards on a flat place and rub the edges with, for example, a ruler to smooth them.

### Envelopes

Envelopes should be fed in the face-up position, right edge first.

Since the composition of an envelope is more complex than that of ordinary paper, it is not always possible to ensure consistent printing quality over the entire envelope surface.

Normally, envelopes have a diagonal grain direction. Refer to *Paper Grain* on page 1-6. This direction can easily cause wrinkles and creases when envelopes pass through the printer. Before purchasing envelopes, make a test print to check whether the printer accepts the envelope.

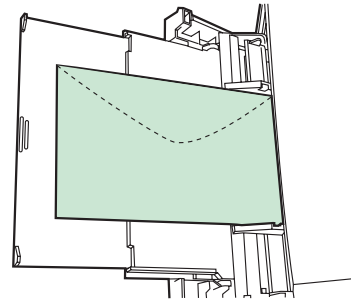

- Do not use envelopes that have an encapsulated liquid adhesive.
- Avoid a long printing session for envelopes only. Extended envelope printing can cause premature printer wear.
- If jams occur, try setting a lesser number of envelopes on the MP tray.
- To avoid jams caused by curled envelopes, stack no more than 10 printed envelopes on the output tray.

### Thick Paper

Fan the stack of paper and align the edges before loading them in the MP tray. Some types of paper have rough edges on the back (those are created when the paper is cut). In this case, put the paper on a flat place and rub the edges once or twice with, for example, a ruler to smooth them. Feeding rough edged paper may cause paper jams.

**NOTE:** If the paper jams even after you smooth it out, load the paper in the *MP Tray* with the leading edge raised up a few millimeters as shown in the illustration.

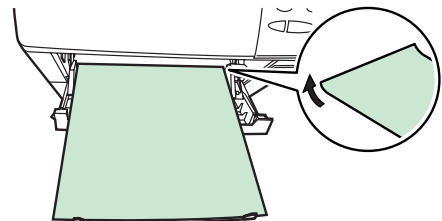

### Colored Paper

Colored paper should satisfy the same conditions as white bond paper, refer to *Paper Specifications*, on page 1-2. In addition, the pigments used in the paper must be able to withstand the heat of fusing during the printing process (up to 200°C or 392°F).

### Preprinted Paper

Preprinted paper should satisfy the same conditions as white bond paper, refer to *Paper Specifications*, on page 1-2. The preprinted ink must be able

to withstand the heat of fusing during the printing process, and must not be affected by silicone oil.

Do not use paper with any kind of surface treatment, such as the type of paper commonly used for calendars.

### Recycled paper

Select recycled paper that meets the same specifications as the white bond paper except for whiteness, refer to *Paper Specifications, on page 1-2*.

---

**NOTE:** Before purchasing recycled paper, test a sample on the machine and check that the printing quality is satisfactory.

---

## Paper Type

The printer is capable of printing under the optimum setting for the type of paper being used.

Setting the paper type for the paper source from the printer's operation panel will cause the printer to automatically select the paper source and print in the mode best suited to that type of paper.

A different paper type setting can be made for each paper source including the MP tray. Not only can preset paper types be selected, but it is also possible for you to define and select customized paper types. Refer to *Creating Custom Paper Type on page 2-74*. The following types of paper can be used.

Paper Type	Paper source			
	MP tray	Paper Cassette	Paper Weight	Duplex path (MP tray available only in Cassette mode)
Plain	Yes	Yes	Normal 2	Yes
Transparency	Yes	No	Extra Heavy	No
Preprinted	Yes	Yes	Normal 2	Yes
Labels	Yes	No	Heavy 1	No
Bond	Yes	Yes	Normal 3	Yes
Recycled	Yes	Yes	Normal 2	Yes
Vellum	Yes	No	Light	No
Rough	Yes	Yes	Normal 3	Yes
Letterhead	Yes	Yes	Normal 3	Yes
Color	Yes	Yes	Normal 2	Yes
Prepunched	Yes	Yes	Normal 2	Yes
Envelope	Yes	No	Heavy 3	No
Cardstock	Yes	No	Heavy 3	No
Thick	Yes	No	Heavy 3	No
High quality	Yes	Yes	Normal 2	Yes
Custom 1 (to 8) <sup>†</sup>	Yes	Yes	Normal 2	Yes
Yes: Can be stored    No: Cannot be stored				

†. This is a paper type defined and registered by the user. Up to eight types of user settings may be defined. For details, refer to *Creating Custom Paper Type on page 2-74*.

## Loading Paper

The following explains the procedure for loading paper in the cassette and the MP tray.

### Loading Paper into the Cassette

The paper cassette can accommodate A6 (FS-2000D: A5) to A4/Letter and Legal size paper and can hold approximately 500 sheets.

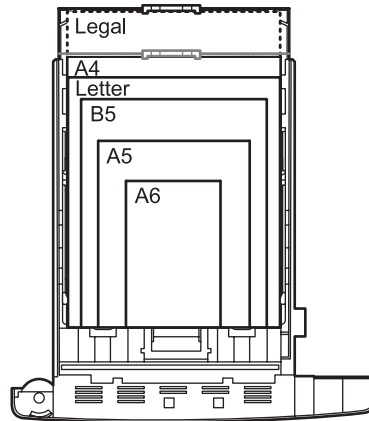

- 1 Pull the paper cassette all the way out of the printer.

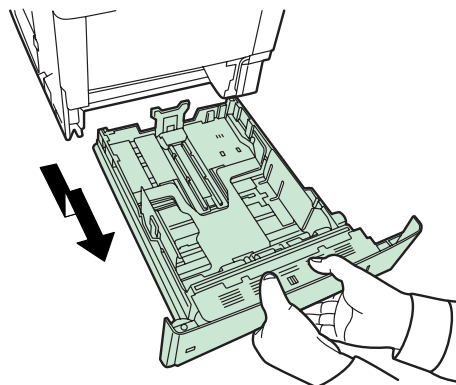

Standard paper sizes are marked on the inside of the paper cassette.

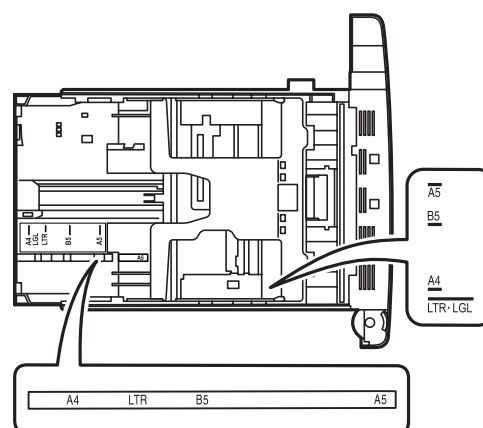

- 2 Turn the paper size dial so that the size of the paper you are going to use appears in the paper size window.

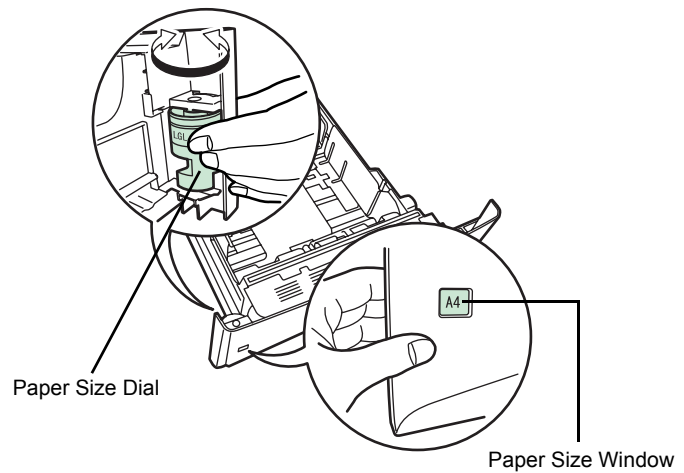

---

**NOTE:** When the paper size dial is set to OTHER the paper size must be set into the printer on the operation panel. Refer to *Setting the Cassette Paper Size* on page 2-67.

---

- 3 Pull the release lever on the left side guide and slide to the desired paper size.

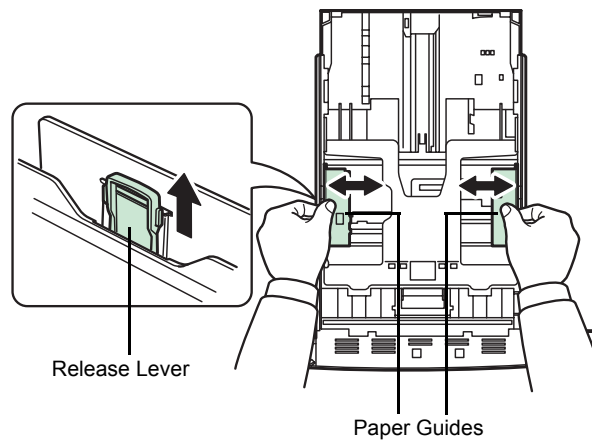

- 4** If you are going to set paper that is longer than A4, pull out the extension paper cassettes pushing the lock lever one by one and adjust them to the desired paper size.

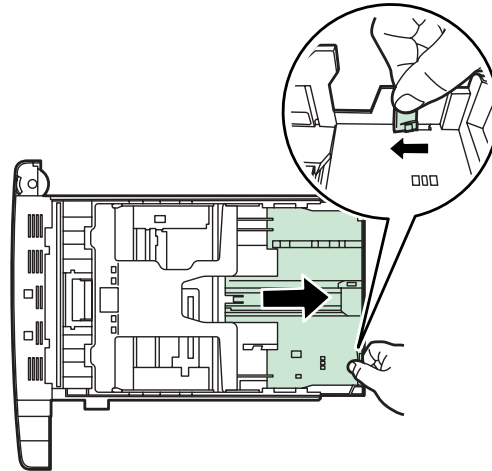

- 5** Pull the release lever and slide the paper stopper to the desired paper size.

When using non-standard size paper, move the paper guides and paper stopper all the way out, insert the paper, then adjust the paper guides and paper stopper to the size of the paper. Adjust them so that they are in light contact with the paper.

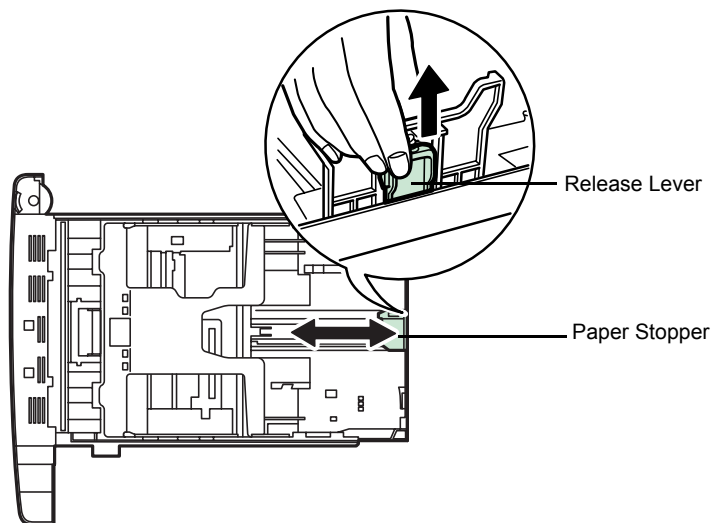

- 6** Push the bottom plate down until it locks (FS-2000D only).

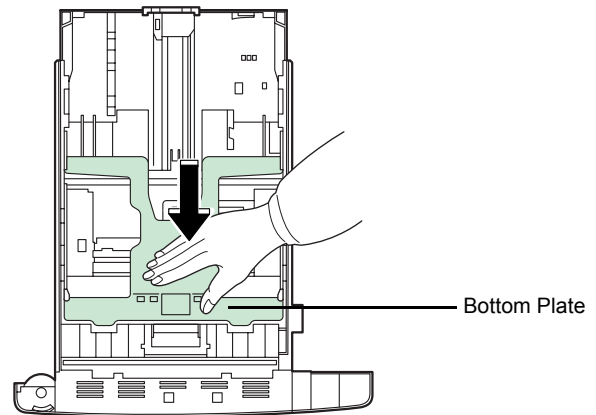

- 7** Fan the paper, then tap it on a level surface to avoid media jams or skewed printing.

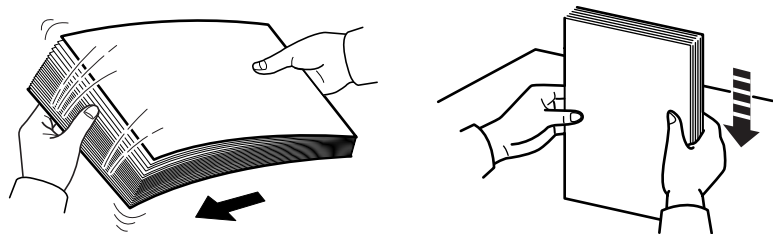

- 8** Place the paper in the paper cassette. Ensure the side to be printed is facing down and the paper is not folded, curled, or damaged.

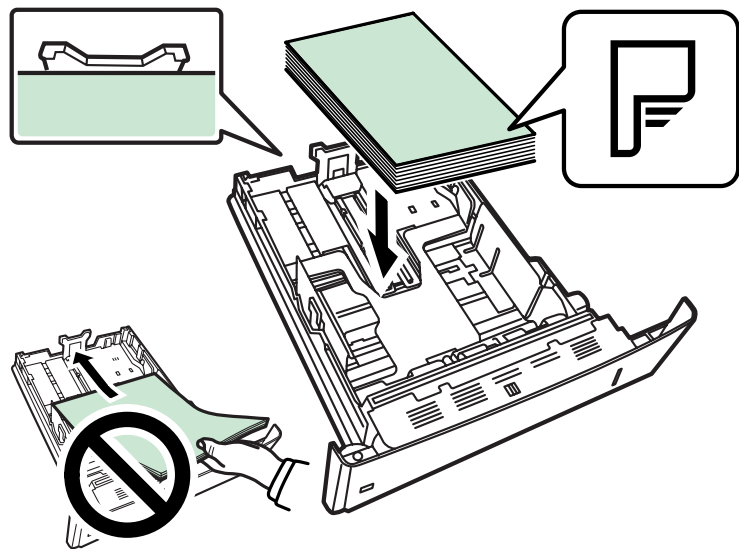

**NOTE:** Do not load more paper than will fit under the load limits on the paper guides.

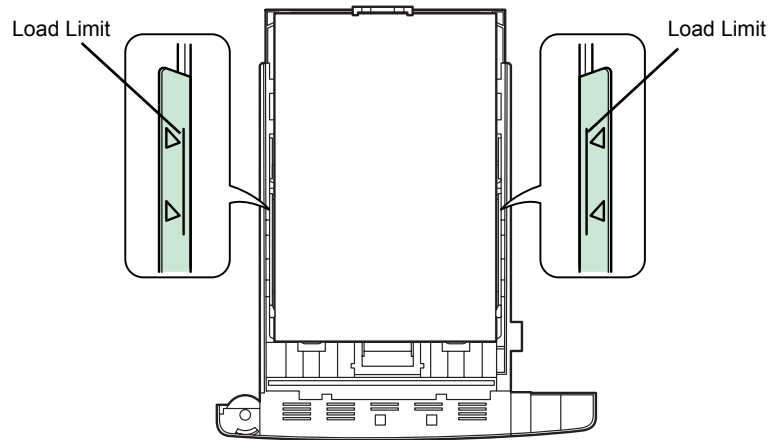

**9** Set the stack of paper so that it is under the clips as shown.

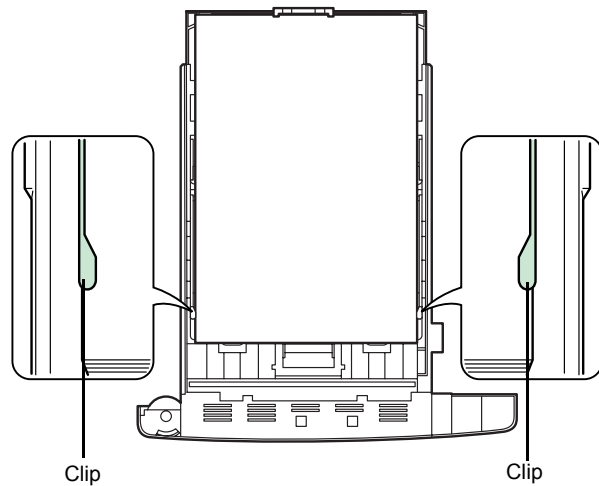

**10** Insert the paper cassette into the slot in the printer. Push it straight in as far as it will go.

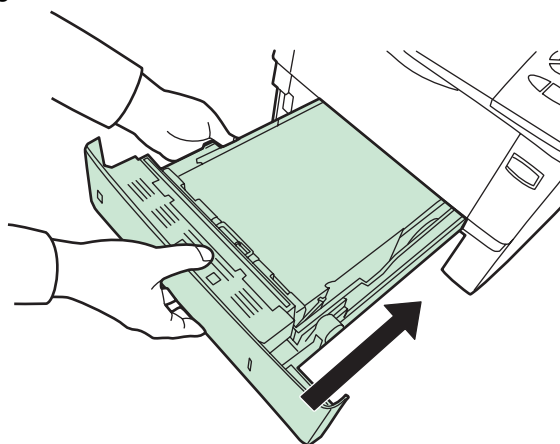

There is a paper gauge on the right side of the front of the paper cassette to indicate the remaining paper supply. When paper is exhausted, the pointer will go down to the level of  (empty).

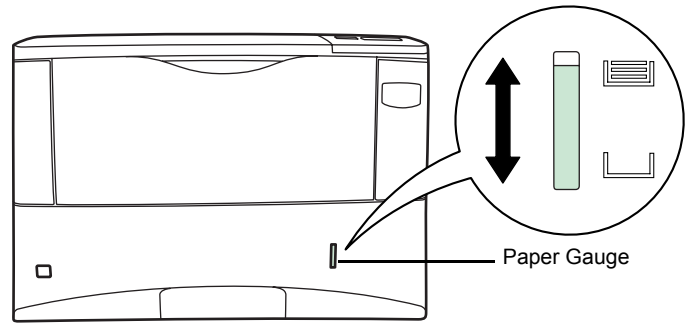

### Loading Paper into the MP (Multi-Purpose) Tray

The MP tray can accommodate the various paper sizes and can hold approximately 100 sheets of paper.

- 1 Fan the media (paper/transparencys), then tap it on a level surface to avoid media jams or skewed printing.

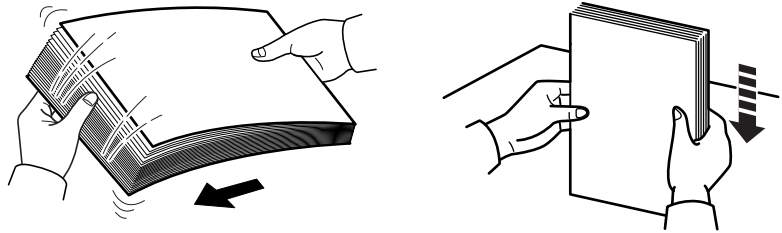

- 2 Pull the MP tray towards you until it stops.

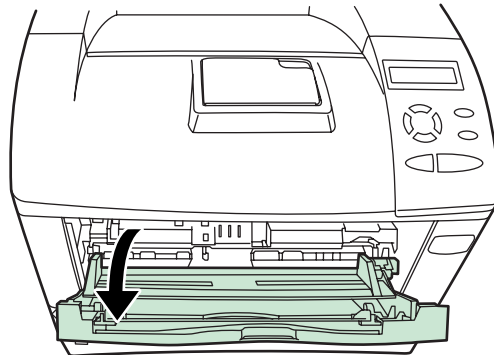

- 3** Pull out the subtray.

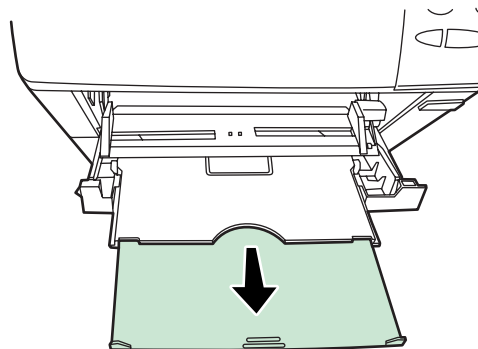

- 4** Adjust the position of the paper guides on the MP tray. Standard paper sizes are marked on the MP tray. For standard paper sizes, slide the paper guides to the position marked correspondingly.

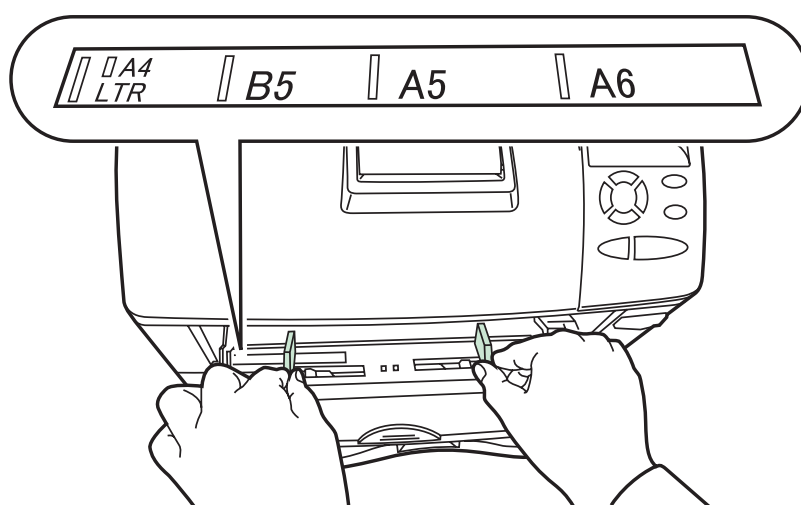

- 5** Align the paper with the paper guides and insert as far as it will go.

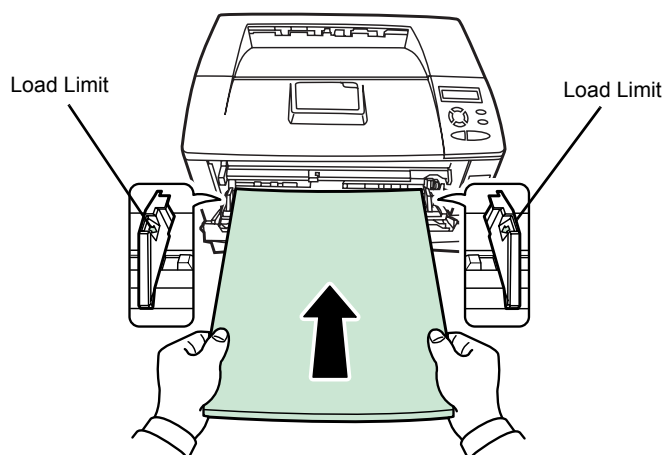

**NOTE:** Do not load more paper than will fit under the load limits on the inside of the MP tray.

If the paper is considerably curled in one direction, for example, if the paper is already printed on one side, try to roll the paper in the opposite direction to counteract the curl. Printed sheets will then come out flat.

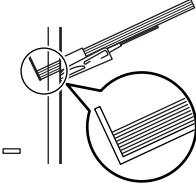
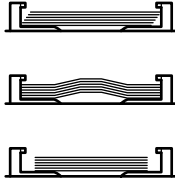
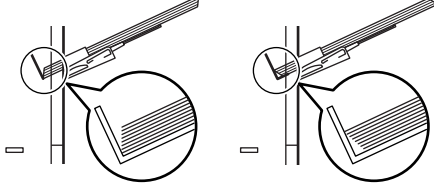
<b>Correct</b>		
<b>Incorrect</b>		

- 6** Set the MP tray paper size on the printer's operation panel. Refer to *Setting MP Tray Paper Size* on page 2-65.

## 2 Using the Operation Panel

This chapter contains explanations on the following topics:

- General Information..... 2-2
- Understanding the Operation Panel..... 2-3
- Canceling a Printing Job ..... 2-10
- Using the Menu Selection System .....2-11
- Status Pages ..... 2-15
- e-MPS ..... 2-19
- Changing the Interface Parameters ..... 2-30
- Making Default Settings ..... 2-38
- Pagination ..... 2-45
- Setting Print Quality..... 2-50
- Operating the Storage Device ..... 2-54
- Paper Handling..... 2-64
- Reading Life Counters..... 2-77
- Other Modes..... 2-78

## General Information

This chapter provides the information you need to configure the Ecosys printer. In general you need to use the operation panel only to make default settings. You can make most changes to the printer settings using the printer driver through the application software.

---

**NOTE:** Changes to printer settings made using a software application override changes made using the operation panel.

---

You can also rely on other printer utilities such as KM-NET for Clients if you need to change settings that are not available on the printer driver. It will allow remote access to printer settings. Printer utilities are supplied in the CD-ROM supplied with the printer.

The chapter describes the operation panel in detail, including its menus and the procedures for changing various printer settings.

## Understanding the Operation Panel

The operation panel on the top of the printer has a 2-line by 16-character liquid crystal display (LCD), eight keys, and three indicators (LED).

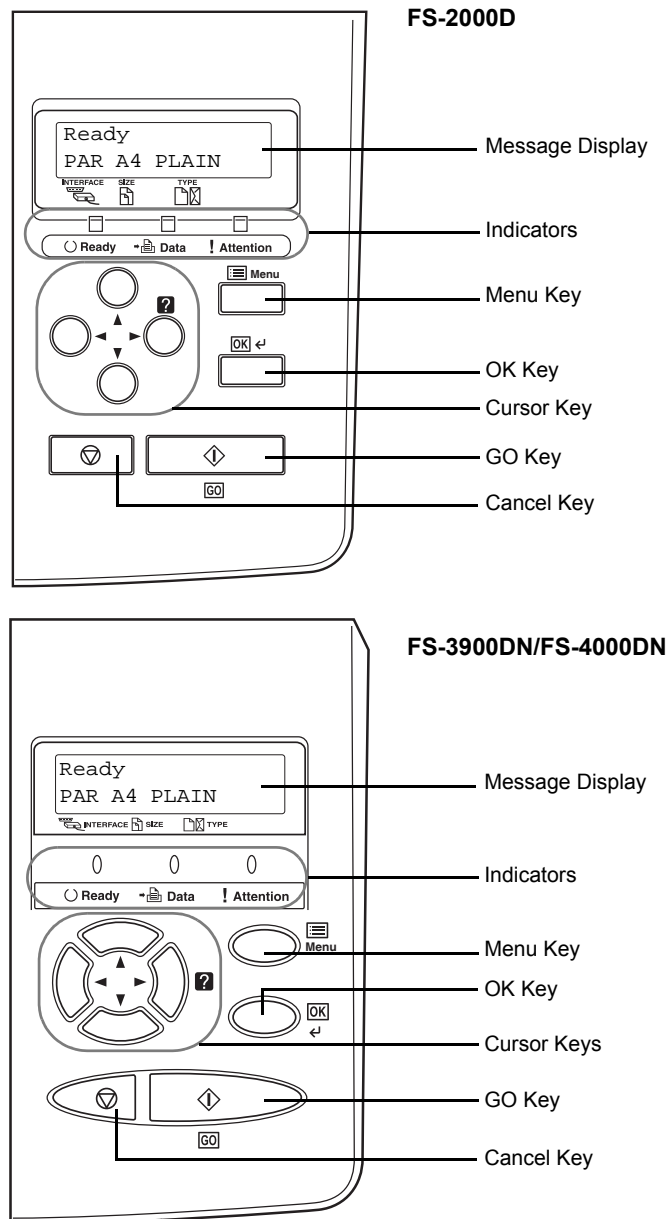

Messages that appear on the display and functions of indicators and keys are explained in this chapter.

## Message Display

The message display on the operation panel shows:

- Status information, the messages listed below which are displayed during normal operation.
- Error codes, when the printer requires the operator's attention; as explained in the Operation Guide.

### Status Information

Message	Meaning
Self test	The printer is performing self-diagnostics after power-up.
Please wait	The printer is warming up and is not ready. This message may be displayed during continuous printing of a large volume of pages which require a large amount of toner such as with photographs, etc.
Please wait (Adding toner)	Toner is currently being replenished. When the printer is switched on for the first time, this message will take several minutes.
Ready	The printer is ready to print.
Processing	The printer is receiving data to print. This is also shown when the printer is reading a CompactFlash card, Microdrive, RAM disk, or USB flash memory.
Sleeping	The printer is in Auto Sleep. The printer wakes from Auto Sleep whenever a key on the operation panel and <b>[GO]</b> is pressed, the cover is opened or closed, or a print job is received. The printer then warms up and goes on-line. For details on Auto Sleep, refer to <i>Sleep Timer Timeout Time on page 2-80</i> .
Skipping data	The printer is skipping the data.
Waiting	The printer is waiting for the rest of print job before completing the last page. Pressing <b>[GO]</b> allows you to obtain the last page immediately. Refer to below.
FormFeed TimeOut	The printer is printing the last page after a waiting period.

### Error codes

Refer to the *Troubleshooting* section in the *Operation Guide*.

## Indicators in Message Display

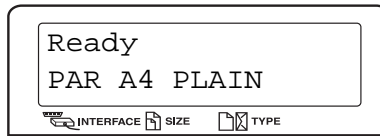

### Interface Indicator (INTERFACE)

The interface indicator shows the interface that is currently in use:

<b>PAR</b>	Parallel interface is in use.
<b>USB</b>	USB interface is in use.
<b>SER</b>	Serial (RS-232C) interface is in use. (option)
<b>NET</b>	Network interface is in use. (FS-2000D: appears only when the optional network interface card IB-30 is installed.)
<b>OPT</b>	Network interface is in use. (option)
---	No interface is in use.

Each interface has a timeout time of 30 seconds (factory default) during which the other interface should wait to receive a print job. Even after a print job has been completed on the interface, you should wait for this period until the other interface begins printing the job.

### Paper Size Indicator (SIZE)

This indicator shows:

- While the printer is in standby, the paper size of the current cassette. The default paper cassette is determined by the operation panel keys. For details, refer to *Paper Handling on page 2-64*.
- While the printer is printing, the paper size used to format the document to print by the application software.

The abbreviations used to indicate the paper sizes and their dimensions are as follows:

A4	ISO A4 (210 × 297mm)
A5	ISO A5 (148 × 210mm)
A6	ISO A6 (105 × 148mm) <sup>†</sup>
B5	JIS B5 (182 × 257mm)
B6	JIS B6 (128 × 182mm) <sup>††</sup>
L/T	Letter (8 1/2 × 11 inches)
L/G	Legal (8 1/2 × 14 inches)

MO	Envelope Monarch (3 7/8 × 7 1/2 inches) <sup>††</sup>
DL	Envelope DL (110 × 220mm) <sup>††</sup>
C5	Envelope C5 (162 × 229mm)
b5	ISO B5 (176 × 250mm)
EX	Executive (7 1/4 × 10 1/2 inches)
#6	Envelope #6 (3 5/8 × 6 1/2 inches) <sup>††</sup>
#9	Envelope #9 (3 7/8 × 8 7/8 inches) <sup>††</sup>
10	Envelope #10 (4 1/8 × 9 1/2 inches) <sup>††</sup>
HA	Hagaki (100 × 148mm) <sup>††</sup>
OH	Oufuku Hagaki (148 × 200mm) <sup>††</sup>
O2	Oficio II (8 1/2 × 13 inches)
16K	16 kai (197 × 273mm)
ST	Statement (5 1/2 × 8 1/2 inches) <sup>††</sup>
FO	Folio (210 × 330mm)
Y2	Yokei 2 (114 × 162mm) <sup>††</sup>
Y4	Yokei 4 (105 × 235mm) <sup>††</sup>
CU	Custom Size Cassette: 105 × 148 to 216 × 356mm [4 1/8 × 5 13/16 to 8 1/2 × 14"] (FS-2000D: 148 × 210 to 216 × 356mm [5 13/16 × 8 1/4 to 8 1/2 × 14"], MP Tray: 70 × 148 to 216 × 356mm [2 3/4 × 5 13/16 to 8 1/2 × 14"])

†. Only with MP tray feeding (FS-2000D)

††. Only with MP tray feeding

### Paper Type Indicator (TYPE)

This indicator shows the paper type defined for the current paper cassette. The paper type can be manually defined using the operation panel. For more information, refer to *Paper Handling on page 2-64*. The following abbreviations are used:



(none)	Auto
PLAIN	Plain paper
TRANSP.	Transparency <sup>†</sup>
PREPRINT	Preprinted paper
LABELS	Labels <sup>†</sup>
BOND	Bond paper
RECYCLED	Recycled paper

VELLUM	Vellum†
ROUGH	Rough paper
LETTERHD	Letterhead
COLOR	Colored paper
PREPUNCH	Prepunched paper
ENVELOPE	Envelope†
CARDSTOCK	Card stock†
THICK	Thick paper†
HIGH QLT	High-quality paper for color printing
CUSTOM 1 (to 8)	Custom 1 (to 8)

†. Only with MP tray feeding

### READY, DATA, and ATTENTION Indicators

The following indicators light during normal operation and whenever the printer needs attention. Depending on the status of lighting, each indicator has the following meaning:

Indicator	Description
 <b>Ready</b>	<p><b>Flashing.</b> Indicates an error that you can resolve. For details, refer to the <i>Troubleshooting</i> section in the <i>Operation Guide</i>.</p> <p><b>On.</b> Indicates that the printer is ready and on-line. The printer prints the data it receives.</p> <p><b>Off.</b> Indicates that the printer is off-line. Data can be received but will not be printed until the printer is switched on-line by pressing <b>[GO]</b>. Also, indicates when printing is automatically stopped due to an error condition. For details refer to the <i>Troubleshooting</i> section in the <i>Operation Guide</i>.</p>
 <b>Data</b>	<p><b>Flashing.</b> Indicates that a data is being received.</p> <p><b>On.</b> Indicates either that data received is being processed before printing starts, or that data received is being written to a CompactFlash card, Microdrive or RAM disk.</p>
 <b>Attention</b>	<p><b>Flashing.</b> Indicates that the printer requires maintenance or is warming up.</p> <p><b>On.</b> Indicates the occurrence of a problem or an error. For details, refer to the <i>Troubleshooting</i> section in the <i>Operation Guide</i>.</p>

## Keys

The operation panel keys are used to configure the printer operation. Note that certain keys have a secondary function.

---

**NOTE:** The printer has a parallel, USB, network, and an optional interface. Configuration of the printer settings affect only the interface that is currently active (shown by the INTERFACE indicator on the message display). Refer to *Interface Indicator (INTERFACE)* on page 2-5.

---

### **GO Key**

**GO** switches the printer between on-line and off-line. Use this key to:

- Toggle the printer's on-line and off-line states. You can temporarily stop the print job by switching the printer off-line.
- Print and feed out one page when the printer displays `Waiting`.
- Recover from certain errors.
- Recover from Auto Sleep.

### **(Cancel) Key**

This key is used to:

- Cancel a printing job.
- Stop the alarm sound.
- Reset numeric values or cancel a setting procedure while using menu system.

#### **1** While the printer displays `Processing`, press **[Cancel]**.

`Print Cancel?` appears on the message display followed by the interface in use. The interface is indicated by one of the following message:

```
Parallel
USB
Network (FS-3900DN/FS-4000DN only)
Serial (option serial interface)
Option (option network interface)
```

#### **2** Press **[OK]**. `Cancelling data` appears on the message display and printing stops after the current page is printed.

### **Menu Key**

**Menu** lets you enter the menu system to change the setup and printing environment of the printer.

Pressing this key during a menu selection will terminate the selection and return the printer to the normal operation.

### Cursor Keys

The four cursor keys are used in the menu system to access an item or enter numeric values.

The arrow key with the question mark (  ) may be pressed when the paper jam message has appeared on the message display. A help message will then appear to facilitate jam clearing in the location.

### OK Key

This key is used to:

- Finalize settings of numeric values and other selections.
- Set the paper source when `Use alternative?` is shown in the message display.

---

**NOTE:** If you hold down **[OK]** and press **[Menu]** when `Ready` is shown on this printer, the AdministrationID menu will be displayed. This menu is the setting menu for administration under the Account Management System and is normally not used. Press **[Menu]** to return to `Ready`.

---

## Canceling a Printing Job

- 1 While the printer displays `Processing`, press **[Cancel]**.

`Print Cancel?` appears on the message display followed by the interface in use. The interface is indicated by one of the following messages:

`Parallel`

`USB`

`Network` (FS-2000D: appears only when the optional network interface card IB-30 is installed.)

`Serial` (option serial interface)

`Option` (option network interface)

- 2 Press **[OK]**. `Cancelling data` appears on the message display and printing stops after the current page is printed.

## Using the Menu Selection System

### Menu Selection System

This section explains how to use the menu selection system. **[Menu]** on the operation panel allows you to use the menu to configure the printer settings to your specific needs. Settings can be made when Ready is indicated on the printer message display.

**NOTE:** Settings that are received from application software and the printer driver will take priority over settings made in the operation panel.

### Entering the Mode Selection Menu

Press **[Menu]** when Ready is indicated on the printer message display.

The mode selection menu is displayed.

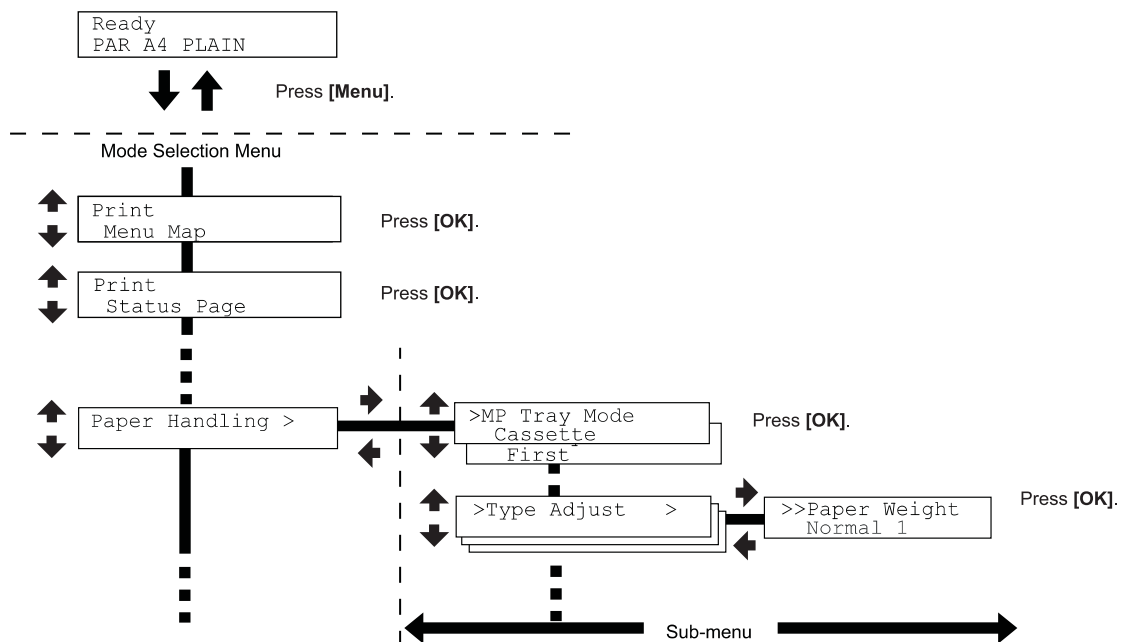

### Selecting a Menu

The mode selection menu is hierarchical. Press **▲** or **▼** to display the desired menu.

If the selected menu has a sub-menu, **>** is displayed after the menu.

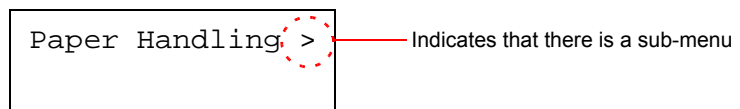

Press **▶** to move to the sub-menu or **◀** to go back.

> is displayed before the sub-menu.

Indicates that this is the sub-menu

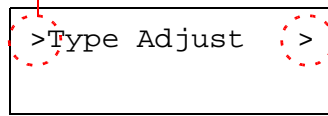

Indicates that there is another sub-menu

Press  $\blacktriangledown$  to move to another sub-menu or  $\blacktriangleleft$  to go back.

>> is displayed before the second sub-menu.

Indicates that this is the second sub-menu

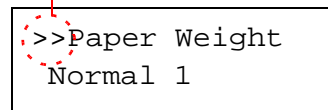

### Setting a Menu

Select the desired menu and press **[OK]** to set or change the configuration.

Press  $\blacktriangleup$  or  $\blacktriangledown$  to display the desired item and **[OK]** to finalize the value or selections set.

### Cancelling Menu Selection

If you press **[Menu]** when a menu is selected, the message display returns to Ready.

## Menu System Road Map

The menu map is the hierarchy diagram of the menu selection system of the printer. The menu map is useful as a reference to guide yourself through the menu selection system.

### Printing a Menu Map

The printer prints a full list of the menu selection system — Menu Map. Note that menus shown in the list may vary depending on which optional units installed in the printer.

**1** Press **[Menu]**.

**2** Press **▲** or **▼** repeatedly until `Print Menu Map` appears.

```
Print
Menu Map
```

**3** Press **[OK]**. A question mark (?) appears.

```
Print
Menu Map ?
```

**4** Press **[OK]**. The message `Processing` appears and the printer prints a Menu Map.

Menu Map Sample

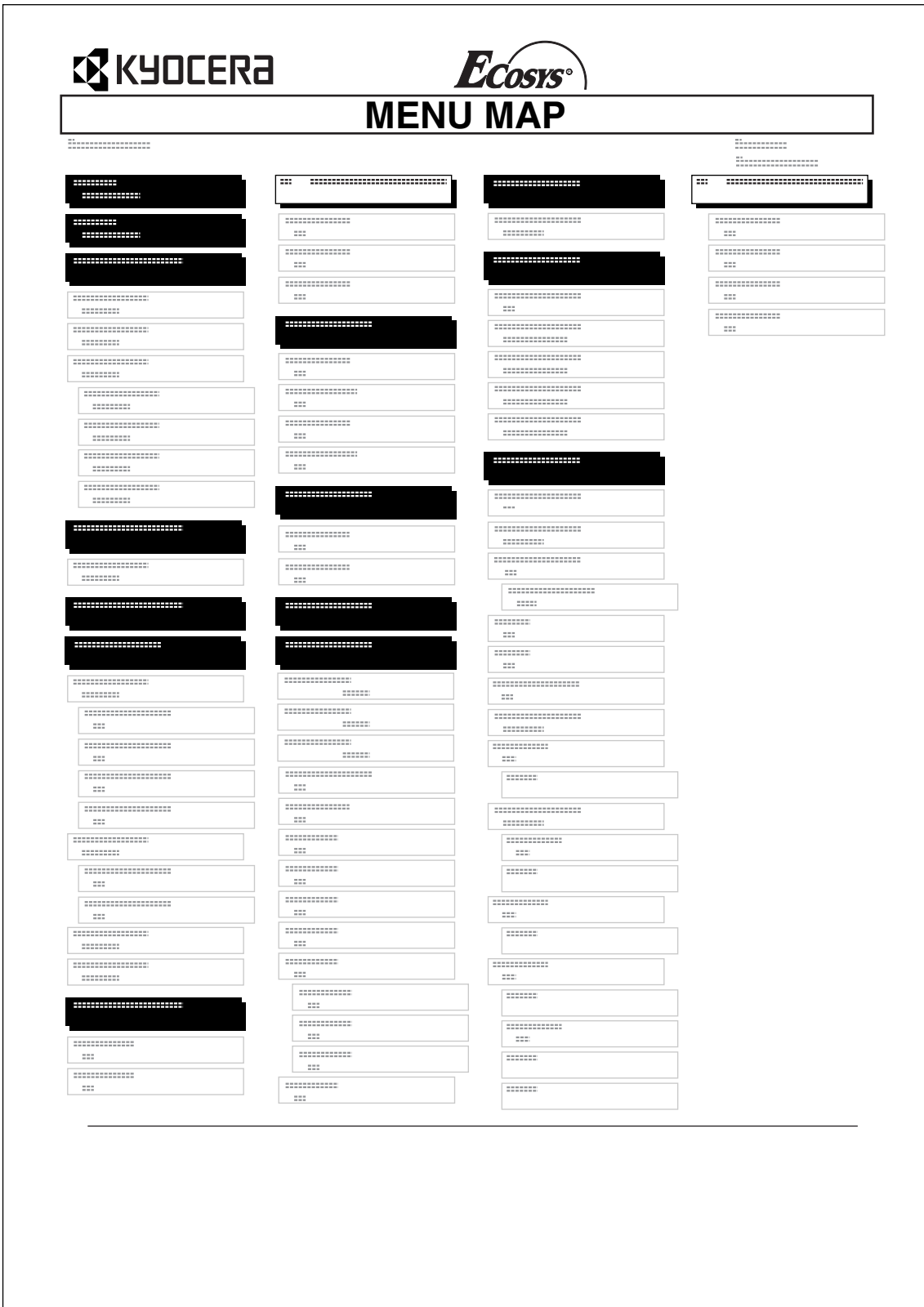

## Status Pages

This section explains the procedure for printing the status pages. The status page is a list of parameters and settings for most basic printer configurations. You may be required to produce a status page when requesting service to the printer.

### Printing a Status Page

You can check the printer's current status, including available memory space and option settings by printing a status page.

- 1 Press **[Menu]**.
- 2 Press **▲** or **▼** repeatedly until `Print Status Page` appears.
- 3 Press **[OK]**. A question mark (?) appears.
- 4 Press **[OK]** again. The message `Processing` appears and the printer prints a status page.

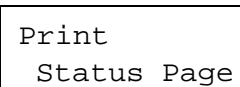

Print  
Status Page

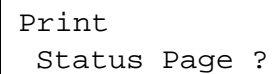

Print  
Status Page ?

For a sample status page and its full description, refer to *Understanding the Status Page* on page 2-16.

## Understanding the Status Page

The numbers in the following diagram refer the items explained below the diagram. The items and values on the status page may vary depending on the printer's firmware version.

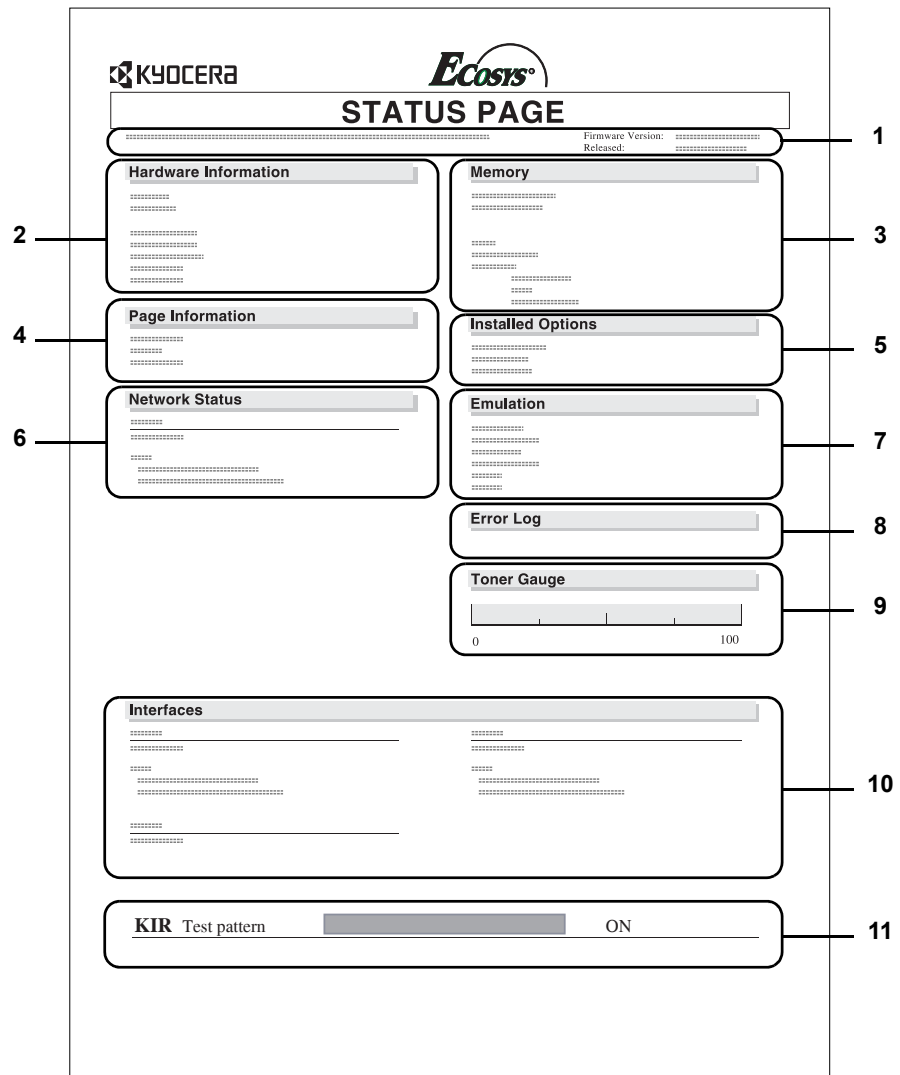

### 1 Firmware Version

This item shows the version and release date of the printer firmware.

### 2 Hardware Information

This item shows various printer settings for hardware-related items:

- MP tray paper size and type
- Paper cassette size and type
- Buzzer control
- Host buffer size

- Sleep time timeout time
- Formfeed timeout time

### **3 Memory**

This item shows:

- Standard memory in the printer
- Option memory slot status in kilobytes
- Total memory in the printer
- Current status of the RAM disk

### **4 Page Information**

This item shows the page related items:

- Number of copies, from 1 to 999
- Total page count

### **5 Installed Options**

This item shows the options installed in the printer:

- Hard disk
- Memory card (CompactFlash card)
- USB memory

### **6 Network Status**

This item shows the IP address, subnet mask address, and default gateway address for the network interface card in the printer.

### **7 Emulation**

This item shows all available emulations of the printer. The PCL 6 emulation is set as default when the printer is shipped from the factory. The emulations are:

- PCL 6
- KPDL3
- Line Printer
- IBM Proprinter
- DIABLO 630
- EPSON LQ-850

### **8 Error Log**

This item shows the last three instances of the following types of errors, listing them in the order of occurrence:

- KPDL (PostScript) errors
- Memory overflow
- Print overrun
- File-not-found

The most recent error is displayed on the topmost line of the Error Log. Error information is cleared when the printer is powered off.

The error log information is intended for service use.

**9 Consumable Status**

This item shows the approximate level of remaining toner. When the value is 100, the toner container is full. The closer to 0, the smaller the amount of remaining toner.

If you use non-original toner kit, the toner gauge measurement will not be indicated correctly.

**10 Interface Information**

This information shows the emulation and the default font for all interfaces installed in the printer.

**11 KIR Test Pattern**

KIR is the Kyocera's original smoothing function. This test pattern shows the effect of the KIR (Kyocera Image Refinement) system.

## e-MPS

e-MPS is an abbreviation for *enhanced-Multiple Printing System* which implements the following functions that are available from the printer driver:

- Job Retention
- Job Storage

In either job mode, when printing a document, the print data is transferred from the computer to the printer then stored on the printer's hard disk. Since copies of the document are printed using the stored data, printing is performed faster with less computer spooling time and less network traffic.

**NOTE:** To use the e-MPS system, an optional Microdrive must be installed in the printer. For details, refer to *Microdrive (Hard Disk)/ CompactFlash (Memory) Card* on page 3-6.

The RAM disk may also be used in the Proof-and-Hold and Private Print modes. Refer to *Using the RAM Disk* on page 2-61 for details on RAM disk setup.

### Job Retention

Job Retention has four modes as summarized below. These modes are selected from the printer driver through the application software:

	Quick Copy	Proof-and-Hold	Private Print	Stored Job
Primary function	To later print additional copies	To proof the first copy before printing multiple copies	To hold the document in printer to prevent unauthorized access	To electronically store documents such as fax cover pages
Start storing by	Printer driver	Printer driver	Printer driver	Printer driver
On terminating print setting from application software	Prints simultaneously	Prints one copy simultaneously	Does not print	Does not print
Retrieved by	Operation Panel	Operation Panel	Operation Panel	Operation Panel
Default number of copies printed at retrieval	Same as storing (can be changed)	One less (can be changed)	Same as storing (can be changed)	One (can be changed)
Maximum number of jobs stored <sup>†</sup>	32, expandable to 50	32, expandable to 50	Depends on the Microdrive capacity	Depends on the Microdrive capacity
PIN security	No	No	Yes	Yes (if necessary)
Data after printing	Stored	Stored	Deleted	Stored
Data at power off	Deleted	Deleted	Deleted	Stored

†. Jobs in excess will cause the earlier ones to be deleted.

### Job Storage

Job storage stores print jobs either temporarily or permanently, or in virtual mailboxes, as you click an appropriate radio button on the printer driver when printing from a computer.

### Virtual Mailbox

Virtual mailbox is part of Job Storage, which stores print jobs on the Microdrive without printing. It enables you to retrieve jobs later from the operation panel.

Each mailbox may be used by an individual who desires to share the printer in this mode. By default, each mailbox is numbered from 'Tray 001,' 'Tray 002,'... etc. To 'post' a job in one of these mailboxes, you assign a numbered or named mailbox on the printer driver when printing.

To retrieve the stored job for printing, refer to *Retrieving Jobs from Virtual Mailbox (VMB) on page 2-24*.

---

**NOTE:** The virtual mailbox can be used in PCL 6 emulation only.

---

## Using Quick Copy

This mode enables you to print the requested number of copies of a job, simultaneously storing the job on the Microdrive. When additional copies are required, you can reprint the required number of copies from the printer operation panel.

The default number of print jobs that can be stored on the Microdrive is 32. This value can be increased to up to 50 from the e-MPS Configuration menu. For details, refer to *Changing the Maximum Number of Quick Copy/Proof-and-Hold Jobs on page 2-26*. When the number of jobs reaches the limit, the oldest job will be overwritten by the new one. When the printer is turned off, all stored jobs will be deleted.

### Printing Additional Copies using Quick Copy

**1** Press **[Menu]**.

**2** Press **▲** or **▼** repeatedly until e-MPS > appears.

e-MPS	>
-------	---

**3** Press **▶**.

**4** Press **▲** or **▼** repeatedly until >Quick Copy appears followed by the user name (Harold, in this example). The user name is assigned at printing using the printer driver.

>Quick Copy Harold
-----------------------

- 5** Press **[OK]**. A blinking question mark (?) appears before the user name.

```
>Quick Copy
?Harold
```

- 6** Press **▲** or **▼** to display the desired user name, *Arlen*, in this example.

```
>Quick Copy
?Arlen
```

- 7** Press **[OK]**. The job name entered in the printer driver (*Report*, in this example) appear with a blinking question mark (?) before the letters.

```
>Arlen
?Report
```

- 8** Press **▲** or **▼** to scroll to the desired job title.

- 9** Press **[OK]**. The number of copies to be printed can be set. To increase the copy count, press **▲**; to decrease the copy count, press **▼**.

```
>Report
Copies      001
```

- 10** Press **[OK]** to finalize the copy count. The printer prints the specified number of copies for the job.

#### Deleting a Quick Copy Job

- 1** Follow steps 1 through 8 in the above section to let the title of the job to be deleted displayed.

- 2** When the title of the job to be deleted is displayed, e.g. *Report*, press **[OK]**. The cursor below the copy count starts to blink.

```
>Report
Copies      001
```

- 3** Press **▼** repeatedly until *Delete* appears below the title.

```
>Report
Delete
```

- 4** Press **[OK]**. The stored quick copy job is deleted.

## Using Proof-and-Hold

When you print multiple copies, this mode first prints one copy so that you can proof it before continuing to print the remaining copies. Since you can proof the printouts before printing the remaining copies, wastage of paper can be reduced.

The printer prints one copy and, at the same time, saves the print job on the Microdrive/RAM disk. You can also change the number of copies when resuming printing from the operation panel.

When the printer is turned off, all stored jobs will be deleted.

### Printing Remaining Copies of a Proof and Hold Job

Printing a Proof-and-Hold job on the operation panel is similar to printing a quick copy job. Refer to *Printing Additional Copies using Quick Copy on page 2-20*

### Printing a Private Print/Stored Job

In private printing, you can specify that a job is not printed until you release the job from the operation panel. When sending the job from the application software, specify a 4-digit access code in the printer driver. The job is released for printing by entering the access code on the operation panel ensuring confidentiality of the print job.

In the stored job mode, access codes are not mandatory, but can be set on the printer driver if printing with PIN security is required. Then, the access code must be entered on the operation panel to print a stored job. Print data will be stored in the Microdrive after printing.

#### Releasing a Private/Stored Job

**1** Press **[Menu]**.

**2** Press **▲** or **▼** repeatedly until e-MPS > appears.

```
e-MPS      >
```

**3** Press **▶**.

**4** Press **▲** or **▼** repeatedly until >Private/ Stored appears. The name entered in the printer driver (Harold, in this example) also appears.

```
>Private/ Stored
Harold
```

**5** Press **[OK]**. A blinking question mark (?) appears before the user name.

```
>Private/ Stored
?Harold
```

**6** Press **▲** or **▼** to display the desired user name (Arlen, in this example).

```
>Private/ Stored
?Arlen
```

**7** Press **[OK]**. The user name and the job name (Agenda, in this example) entered in the printer driver appear with a blinking question mark (?).

```
>Arlen
?Agenda
```

**8** Press **▲** or **▼** to display the desired job title.

- 9** Press **[OK]**. The ID input line appears. Enter the four-digit access code entered in the printer driver and press **[OK]**.

```
>Agenda
ID          0000
```



To enter the ID, press **▲** or **▼** to move the cursor to the number to be changed and then enter the correct number by pressing **▲** or **▼**.

- 10** You can set the number of copies to be printed. To increase the copy count, press **▲**; to decrease the copy count, press **▼**.

```
>Agenda
Copies      001
```



- 11** Press **[OK]** to finalize the copy count. The printer prints the specified number of copies for the job.

### Deleting a Private/Stored Job

You can individually delete stored jobs by performing the following procedure. Jobs saved using Private Print will be automatically deleted if you turn the power off after printing, but jobs saved using Stored Job will not be deleted automatically.

- 1** Follow steps 1 through 8 in the above section.

- 2** When the title of the job to be printed is displayed (*Agenda*, in this example), press **[OK]**. Enter the four-digit access code entered in the printer driver and press **[OK]**.

```
>Agenda
Copies      001
```



- 3** Press **▼** repeatedly until *Delete* appears for the number of copies.

```
>Agenda
Delete
```



- 4** Press **[OK]**. The private job is deleted from the Microdrive.

### Printing a Code Job

To print a code job, ensure that the **KM-NET for Clients** is installed on the computer. The **KM-NET for Clients** is provided on the Software Library CD-ROM.

### Printing a List of Code Jobs

If you select Permanent Job Storage on the printer driver, you can print a List of Code Jobs using the operation panel.

**1** Press **[Menu]**.

**2** Press **▲** or **▼** repeatedly until e-MPS > appears.



**3** Press **▶**.

**4** Press **▲** or **▼** repeatedly until >List of Code JOB appears.

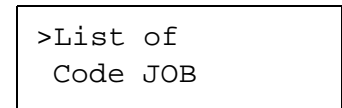

**5** Press **[OK]**. A question mark (?) appears.

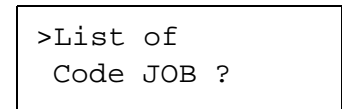

**6** Press **[OK]** again. The printer prints a Code Job list as shown below.

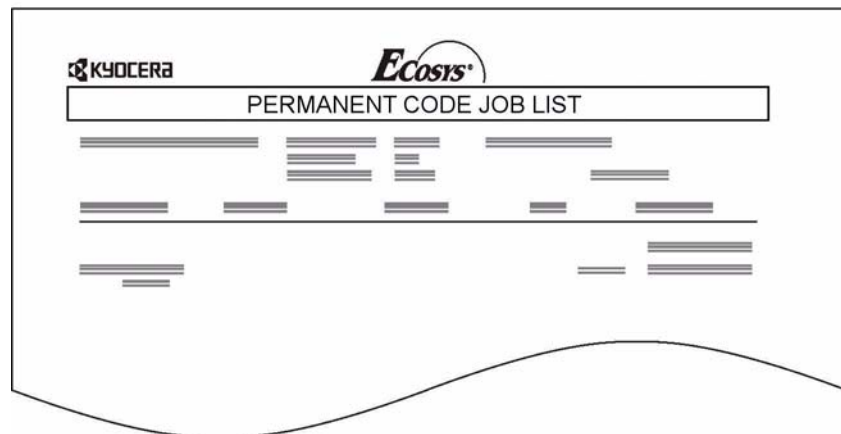

### Retrieving Jobs from Virtual Mailbox (VMB)

**1** Press **[Menu]**.

**2** Press **▲** or **▼** repeatedly until e-MPS > appears.

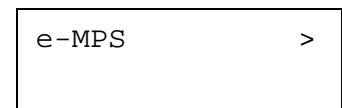

**3** Press **▶**.

- 4** Press **▲** or **▼** repeatedly until **>Print VMB Data** appears. The virtual mailbox number will also appear.

```
>Print VMB Data
Tray001:
```

If you have named the virtual mailbox with an alias, the alias (Richard, in this example) will follow the number:

```
>Print VMB Data
Tray001:Richard
```

- 5** Press **[OK]**. A blinking question mark (?) appears.

```
>Print VMB Data
Tray001?Richard
```

- 6** Press **[OK]**. The document in the mailbox is printed and automatically deleted from the mailbox.

### Printing a List of VMB

A Virtual Mailbox list includes the jobs currently stored in the mailboxes.

- 1** Press **[Menu]**.

- 2** Press **▲** or **▼** repeatedly until **e-MPS >** appears.

```
e-MPS >
```

- 3** Press **▶**.

- 4** Press **▲** or **▼** repeatedly until **>List of VMB** appears.

```
>List of VMB
```

- 5** Press **[OK]**. A question mark (?) appears.

```
>List of VMB ?
```

- 6 Press **[OK]** again. The printer prints a list of jobs currently posted in the virtual mailboxes as shown in the following illustration.

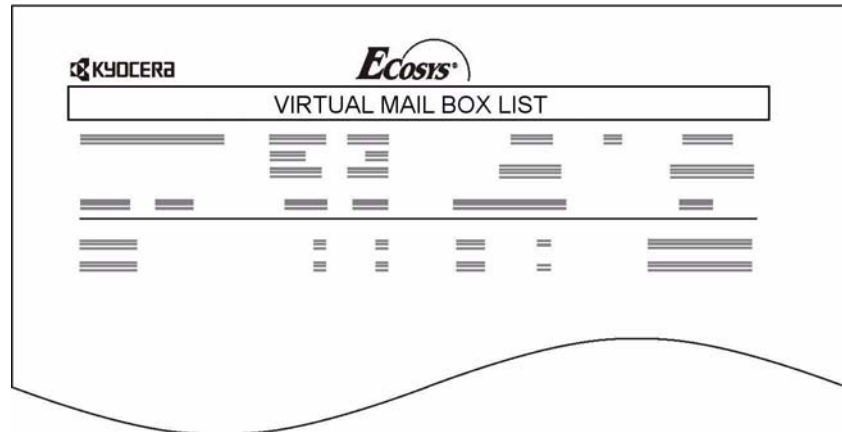

## Changing e-MPS Configuration

You can change the following parameters for e-MPS operation:

- Maximum number of Quick Copy/Proof-and-Hold jobs
- Maximum space assigned to temporary code jobs
- Maximum space assigned to permanent code jobs
- Maximum space assigned to virtual mailboxes

**NOTE:** The total amount of storage areas specified must not exceed the total size of the Microdrive.

### Changing the Maximum Number of Quick Copy/Proof-and-Hold Jobs

This changes maximum number of Quick Copy/Proof-and-Hold jobs from 0 to 50. The default is 32.

- 1 Press **[Menu]**.
- 2 Press **▲** or **▼** repeatedly until e-MPS > appears.
- 3 Press **▶**.
- 4 Press **▲** or **▼** repeatedly until >e-MPS Configuration > appears.
- 5 Press **▶**.

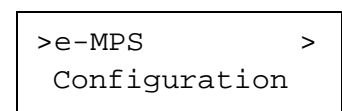

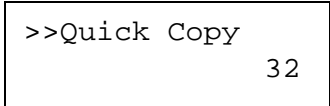
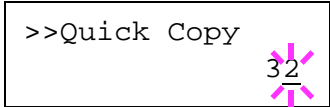
- 6** Press **▲** or **▼** repeatedly until `>>Quick Copy` appears.
- 
- 7** Press **[OK]**. A blinking cursor (`_`) appears.
- 
- 8** Press **▲** or **▼** to increase or decrease the value at the blinking cursor. The value can be set between 0 and 50. Use **▶** and **◀** to move the cursor right and left.
- 9** When the desired maximum number of jobs is set, press **[OK]**.
- 10** Press **[Menu]**. The display returns to `Ready`.

### Maximum Space Assigned to Temporary Code Jobs

This changes the Microdrive space that holds temporary code jobs. You can change the maximum space from 0 to 9999 (megabytes). The actual maximum size depends on the size of free Microdrive space. The default size is 1/6 of the total Microdrive space, rounded off in units of 50MB. For example, if the total Microdrive space is 10GB, the default size is 1550MB.

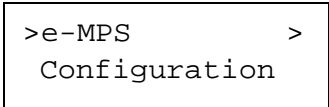
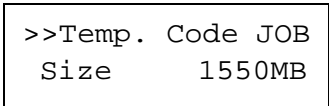
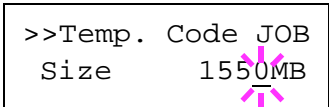
- 1** Press **[Menu]**.
- 2** Press **▲** or **▼** repeatedly until `e-MPS >` appears.
- 
- 3** Press **▶**.
- 4** Press **▲** or **▼** repeatedly until `>e-MPS Configuration >` appears.
- 
- 5** Press **▶**.
- 6** Press **▲** or **▼** repeatedly until `>>Temp. Code JOB Size 1550MB` appears.
- 
- 7** To change the maximum disk space, press **[OK]**. A blinking cursor (`_`) appears.
- 
- 8** Press **▲** or **▼** to increase or decrease, respectively, the value at the blinking cursor. Use **▶** and **◀** to move the cursor right and left.

- 9 When the desired size is displayed, press **[OK]**.
- 10 Press **[Menu]**. The display returns to Ready.

**Maximum Space Assigned to Permanent Code Jobs**

This changes the Microdrive space that holds permanent code jobs. You can change the maximum space from 0 to 9999 (megabytes). The actual maximum size depends on the size of free Microdrive space. The default size is 1/6 of the total Microdrive space, rounded off in units of 50MB. For example, if the total Microdrive space is 10GB, the default size is 1550MB.

- 1 Press **[Menu]**.

- 2 Press **▲** or **▼** and select e-MPS >.



- 3 Press **▶**.

- 4 Press **▲** or **▼** and select >e-MPS Configuration >.

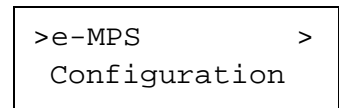

- 5 Press **▶**.

- 6 Press **▲** or **▼** and select >>Perm. Code JOB Size.

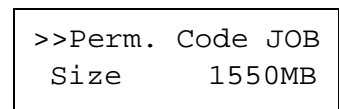

- 7 Press **[OK]**, the message display shows a blinking cursor ( \_ ).

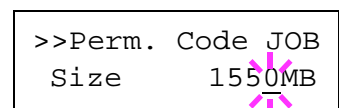

- 8 Press **▲** or **▼** to increase or decrease, respectively, the value at the blinking cursor. Use **▶** and **◀** to move the cursor right and left.

- 9 When the desired size is displayed, press **[OK]**.

- 10 Press **[Menu]** and the display returns to Ready.

### Maximum Space Assigned to Virtual Mailboxes (VMB)

This changes the Microdrive space for virtual mailboxes. You can change the maximum space from 0 to 9999 (megabytes). The actual maximum size depends on the size of free Microdrive space. The default size is 1/6 of the total Microdrive space, rounded off in units of 50MB. For example, if the total Microdrive space is 10GB, the default size is 1550MB.

- 1 Press **[Menu]**.
- 2 Press **▲** or **▼** and select **e-MPS >**.
 

e-MPS >
- 3 Press **▶**.
- 4 Press **▲** or **▼** and select **>e-MPS Configuration >**.
 

>e-MPS Configuration >
- 5 Press **▶**.
- 6 Press **▲** or **▼** and select **>>VMB Size**.
 

>>VMB Size  
1550MB
- 7 To change the maximum size, press **[OK]**. The message display shows a blinking cursor (  ).
 

>>VMB Size  
1550  MB
- 8 Press **▲** or **▼** to increase or decrease, respectively, the value at the blinking cursor. Use **▶** and **◀** to move the cursor right and left.
- 9 When the desired size is displayed, press **[OK]**.
- 10 Press **[Menu]** to exit the menu selection.

## Changing the Interface Parameters

This printer is equipped with a parallel interface, a USB interface and a network interface (FS-3900DN/FS-4000DN). An optional serial interface and a network interface can be installed. Various printing environment parameters such as the default emulation can be changed independently on different interfaces by using the printer's menu selection system. Select the interface to apply the changes in the procedure described below.

**NOTE:** This interface selection described below does not select the interface from which data will be received. The printer automatically selects the interface.

### Changing Parallel Interface Mode

The parallel interface supports a bi-directional/high-speed mode according to IEEE standards. Normally, this interface is used under the default setting `Auto`. For details, refer to *Parallel Interface on page 4-3*. After setting the interface, be sure to reset the printer or turn the power off at least once. The new setting will be enabled thereafter. You can select from the following:

- Auto (default)
- Nibble (high)
- High speed
- Normal

**1** Press **[Menu]**.

**2** Press **▲** or **▼** repeatedly until `Interface >` appears.

**3** If the interface is other than parallel, press **[OK]**. A blinking question mark (?) appears.

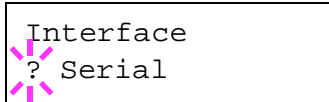

```
Interface
? Serial
```

**4** Press **▲** or **▼** repeatedly until `Parallel` appears.

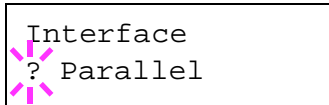

```
Interface
? Parallel
```

**5** Press **[OK]** again. The question mark disappears.

**6** To change the parallel interface mode, press **▶**. The current communication mode appears.

**7** To change the communication mode, press **[OK]**. A blinking question mark (?) appears.

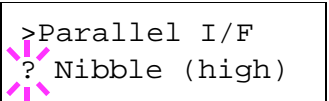

```
>Parallel I/F
? Nibble (high)
```





- 8 Press **▲** or **▼** to scroll through the following communication modes:
  - Nibble (high)
  - Auto
  - Normal
  - High speed
- 9 When the desired communication mode is displayed, press **[OK]**.
- 10 Press **[Menu]** to exit the menu selection.

## Changing Serial Interface Parameters

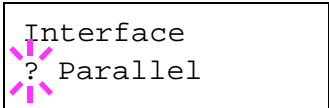
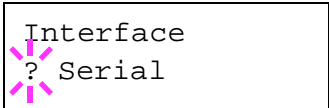
**NOTE:** This section applies to the printer having the optional serial interface board kit (IB-11) installed.

You can confirm or change the serial interface parameters including baud rate, data bits, stop bits, parity, and protocol. These parameters must match those of the computer's serial interface.

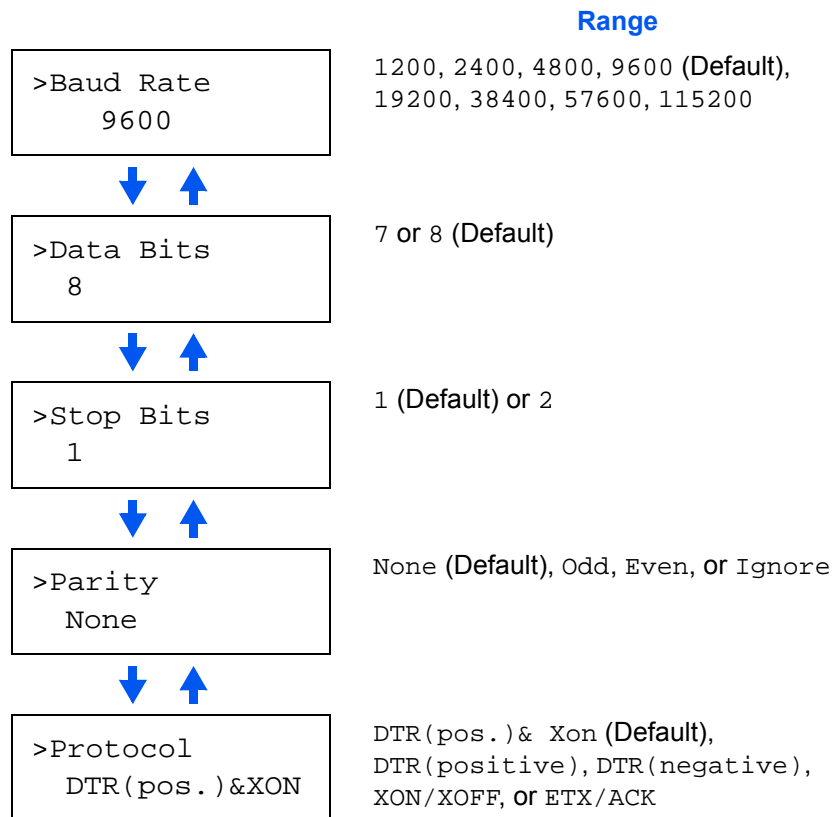

- 1 Press **[Menu]**.
- 2 Press **▲** or **▼** repeatedly until `Interface >` appears.
- 3 If the interface is other than serial, press **[OK]**. A blinking question mark (?) appears.
 
- 4 Press **▲** or **▼** repeatedly until `Serial` appears.
 
- 5 Press **[OK]** again.
- 6 Press **▶**. One of the following serial parameters is indicated (Baud rate for example).

Pressing  or  toggles through the serial parameters as follows. To change the serial parameter, press **[OK]**. Use  or  to change the value or selection.

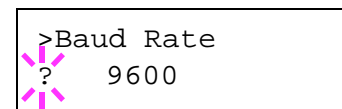

For example, to change baud rate from 9600 to 115200, display the baud rate menu following the above procedure. When the display shows baud rate, 9600 (bps), press **[OK]**. A blinking question mark (?) appears.



- 7** Press  or  to scroll through values. When 115200 is displayed, press **[OK]**. Press **[Menu]** to exit the menu selection.

**NOTE:** Some computers may not be able to handle a baud rate of 115200 bps. If you set the baud rate to 115200 and encounter communication problems, select a lower baud rate.

## Changing Network Interface Parameters

This printer supports TCP/IP, NetWare and AppleTalk protocols. In addition, you can install the optional network interface card in the option interface slot.

**NOTE:** Installing the optional network interface card on the FS-2000D enables the following network settings.

Using the operation panel, you can:

- Activate or deactivate TCP/IP, NetWare, and AppleTalk
- Activate or deactivate DHCP
- Enter IP address, subnet mask address, and default gateway address
- Determine whether to print a network status page when the printer is turned on

**1** Press **[Menu]**.

**2** Press **▲** or **▼** repeatedly until `Interface >` appears.

**3** If the current interface is other than `Network`, press **[OK]**. A blinking question mark (?) appears.

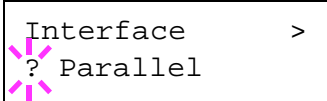

```

Interface >
? Parallel
  
```

If the optional network interface card is installed in the printer, `Option` will be displayed. The setting procedure is basically the same even in this case.

**4** Press **▲** or **▼** repeatedly until `Network` appears.

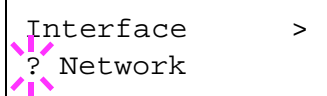

```

Interface >
? Network
  
```

**5** Press **[OK]** again.

- 6 Press **▶**. One of the following menus is indicated. To change settings for the item, press **[OK]**. Use **▲** or **▼** to change the value or selection.

Set this item to **On** when you connect to a network using NetWare. In submenu (>), frame mode can be selected from **Auto**, **802.3**, **Ethernet II**, **802.2**, and **SNAP**.

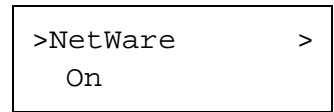

Set this item to **On** when you connect to a network using TCP/IP. Submenu (>) has items including **DHCP**, **BOOTP**, **IP address**, **subnet mask address**, and **gateway address**. To resolve IP address for the network card, refer to *Resolving IP Address on page 2-34*.

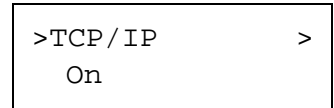

AppleTalk must be activated (**On**) for networking with Macintosh computers.

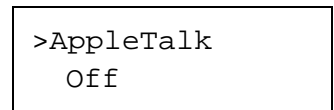

When the item is set to **On**, the printer prints out a network status page when it prints the printer status. refer to *Printing a Network Interface Status Page on page 2-36*.

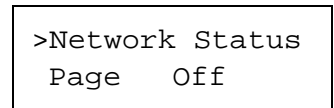

- 7 Activate the appropriate protocol that is required to connect the printer to the network. To activate a protocol, display the protocol, press **[OK]**, press **▲** or **▼** to change from **Off** to **On**, and press **[OK]**.
- 8 Press **[Menu]**. The display returns to **Ready**. You can print a network status page to confirm that the IP address, subnet mask address, and the gateway address have been properly set. To print a network status page, refer to *Printing a Network Interface Status Page on page 2-36*.

## Resolving IP Address

To connect the printer to the network using TCP/IP protocol, you must set the IP address on the printer. The IP address must be unique to the printer and should be obtained from your network administrator.

- 1 Activate TCP/IP protocol in the manner described above.

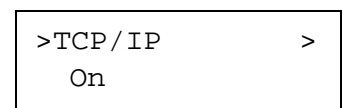

- 2** Enter the submenu by pressing  $\blacktriangledown$ . Each time you press  $\blacktriangle$  or  $\blacktriangledown$ , the selection changes.

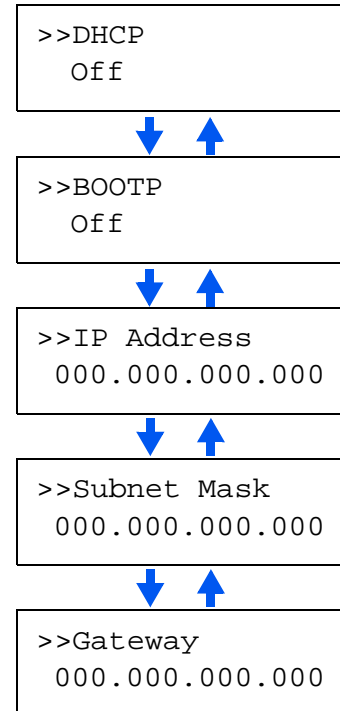

- 3** When  $\text{>>IP Address}$  is displayed, press **[OK]**. A blinking cursor ( $\_$ ) appears at the last digit.

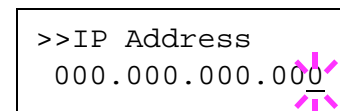

- 4** Press  $\blacktriangle$  or  $\blacktriangledown$  to increase or decrease, respectively, the value at the blinking cursor. Use  $\blacktriangleright$  and  $\blacktriangleleft$  to move the cursor right and left.
- 5** When the IP address is entered, press **[OK]**.
- 6** Press  $\blacktriangle$  or  $\blacktriangledown$  to move to *Subnet Mask*. Perform the same procedure to complete entering the subnet mask address.
- 7** Then, press  $\blacktriangle$  or  $\blacktriangledown$  to move to *Gateway*. Perform the same procedure to complete entering the gateway address.
- 8** Press **[Menu]**. The display returns to *Ready*. You can print a network status page to confirm that the IP address, subnet mask address, and the gateway address have been properly set. To print a network status page, refer to *Printing a Network Interface Status Page on page 2-36*.

### Printing a Network Interface Status Page

You can have your printer print out a network status page when the printer prints the status page. The network status page shows the network addresses, and other information under various network protocols about the network interface card. The default setting is OFF (print disable).

---

**NOTE:** Printing out a network interface status page may not be possible with the optional network interface card. For details, refer to the manual for the network interface.

---

**1** Press **[Menu]**.

**2** Press **▲** or **▼** repeatedly until `Interface >` appears.

**3** If the current interface is other than `Network`, press **[OK]**. A blinking question mark (?) appears.

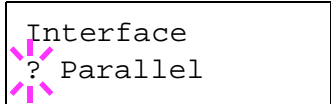

Interface  
? Parallel

**4** Press **▲** or **▼** repeatedly until `Network` appears. Press **[OK]**.

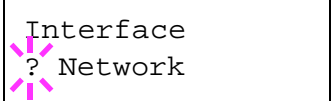

Interface  
? Network

**5** Press **▶** and then press **▲** or **▼** repeatedly until the display shows `>Network Status Page`.

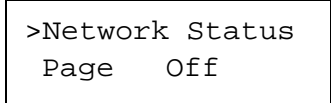

>Network Status  
Page Off

**6** Press **[OK]**. A blinking question mark (?) appears.

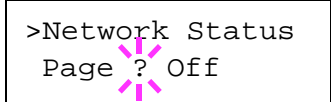

>Network Status  
Page ? Off

**7** Press **▲** or **▼** to select `On`.

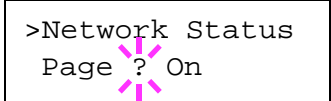

>Network Status  
Page ? On

**8** Press **[OK]** again.

- 9 Press **[Menu]**. The display returns to Ready. The printer prints a network status page as an example shown in the following illustration.

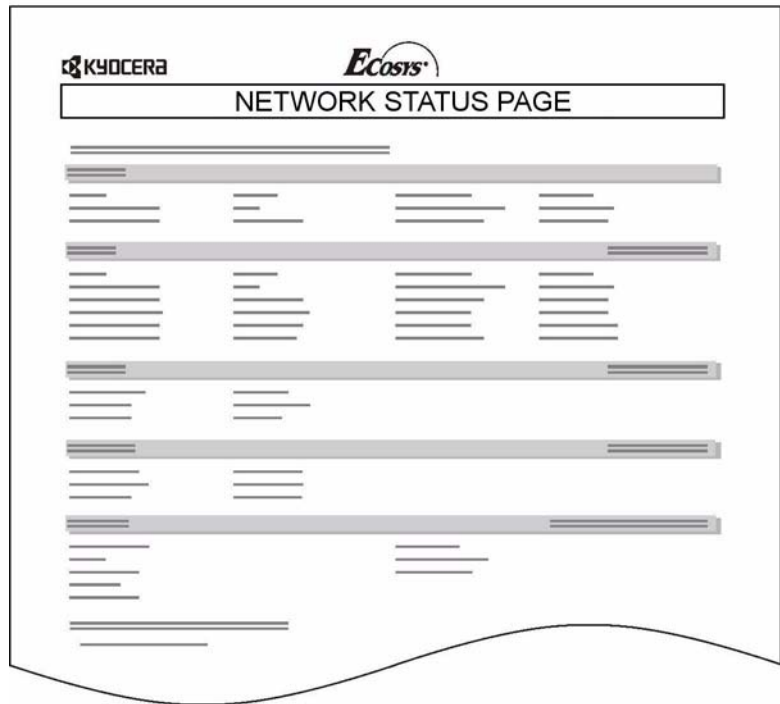

## Making Default Settings

Using the operation panel, you can set the default for the following items.

### Default Emulation

You can change the emulation mode and character code set for the current interface.

The printer can automatically change the emulation mode according to the print job that is received from the computer. To do this, select **KPDL (AUTO)** in the following procedure.

- 1 Press **[Menu]**.
- 2 Press **▲** or **▼** repeatedly until **Emulation >** appears on the message display. One of the emulation modes appears, indicating the emulation currently in use.

```
PCL 6 (default)
KPDL
KPDL (AUTO)
Line Printer
IBM Proprinter
DIABLO 630
EPSON LQ-850
```

To change the default emulation, press **[OK]**. A blinking question mark (?) appears.

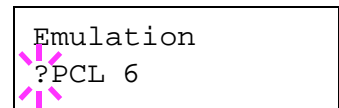

Emulation  
?PCL 6

- 3 Press **▲** or **▼** repeatedly until the desired emulation mode is displayed.
- 4 Press **[OK]**.
- 5 Press **[Menu]**. The display returns to **Ready**.

### Printing KPDLE Errors

The printer can print error descriptions when printing error occurs during KPDLE emulation. The default is **Off** — the printer does not print KPDLE errors.

- 1 Press **[Menu]**.
- 2 Press **▲** or **▼** repeatedly until **Emulation >** appears.
- 3 Press **[OK]**. A blinking question mark (?) appears.

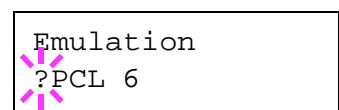

Emulation  
?PCL 6

- 4** Select KPDL or KPDL (AUTO) using **▲** or **▼**.

```
Emulation
?KPDL
```

- 5** Press **[OK]**.

- 6** Press **▶**. Press **▲** or **▼** until >Print KPDL Errs (errors) appears.

```
>Print KPDL Errs
Off
```

- 7** Press **[OK]**. A blinking question mark (?) appears.

```
>Print KPDL Errs
? Off
```

- 8** Select On using **▲** or **▼**. Press **[OK]**.

- 9** Press **[Menu]**. The display returns to Ready.

## Default Font

You can select the default font for the current interface. The default font can be one of the internal fonts or a font that is downloaded to the printer memory or stored on CompactFlash card, Microdrive or option ROM.

In this menu, you can also set the type and pitch for Courier and Letter Gothic; as well as to print a font list.

- 1** Press **[Menu]**.

- 2** Press **▲** or **▼** repeatedly until Font > appears.

```
Font >
```

- 3** Press **▶**. Press **▲** or **▼** until >Font Select > appears.

```
>Font Select >
Internal
```

- 4** To select an internal font, make sure that Internal is displayed and press **▶**. The display changes. If Internal is not displayed, press **[OK]**, then press **▲** or **▼** until it appears.

```
>> I000
```

To select an optional font, press **[OK]** while >Font Select > is displayed. Press **▲** or **▼** repeatedly until Option appears and then press **[OK]**. Press **▶** next to display the font selection shown above. You can perform this operation only when optional fonts are installed in the printer.

The letter before the number indicates the location of the font, as shown below:

- I Internal font
- S Soft (downloaded) font
- M Fonts in optional CompactFlash card
- H Fonts in RAM disk or optional Microdrive
- O Fonts in optional ROM (API)

- 5** Press **[OK]**. A blinking question mark (?) appears.

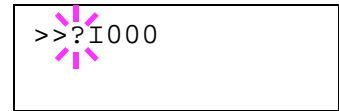

- 6** Press **▲** or **▼** repeatedly until the desired font number appears. For font numbers of the internal fonts, refer to *Printing Lists of Fonts on page 2-43*.

- 7** When the desired font is displayed, press **[OK]**.

- 8** Press **[Menu]**. The display returns to Ready.

### Selecting Regular or Dark Courier/Letter Gothic

Courier or Letter Gothic font thickness can be selected as *Regular* or *Dark*. In the procedure below, it is assumed that Courier is selected. The procedure is the same for Letter Gothic.

- 1** Press **[Menu]**.

- 2** Press **▲** or **▼** repeatedly until *Font >* appears.



- 3** Press **▶**. Press **▲** or **▼** until *>Font Select >* appears.

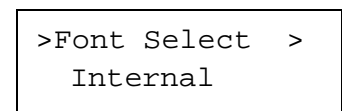

- 4** Make sure that *Internal* is displayed and press **▶**.

- 5** Press **▲** or **▼** repeatedly until *>>Courier* appears. If you are selecting the thickness of the Letter Gothic font, choose *>>Letter Gothic* here instead.

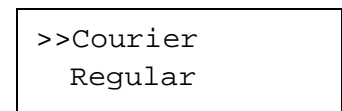

- 6** Press **[OK]**. A blinking question mark (?) appears.

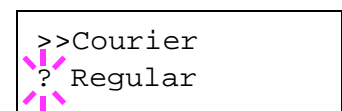

- 7** Select *Regular* or *Dark* using **▲** or **▼**.

- 8 Press **[OK]**.
- 9 Press **[Menu]**. The display returns to Ready.

### Changing the Default Font Size

You can change the size of the default font. If you selected a proportional font, the character size can also be changed.

- 1 Press **[Menu]**.
- 2 Press **▲** or **▼** repeatedly until Font > appears.
 

Font >
- 3 Press **▶**. Press **▲** or **▼** until >Font Select > appears.
 

>Font Select >  
Internal
- 4 Make sure that Internal is displayed and press **▷**.
- 5 Press **▲** or **▼** repeatedly until >>Size appears.
 

>>Size  
012.00 point(s)
- 6 Press **[OK]**. A blinking cursor (|) appears.
 

>>Size  
012.00| point(s)
- 7 Press **▲** or **▼** to increase or decrease the value at the blinking cursor. The font size can be set between 4 and 999.75 points, in 0.25-point increments. Use **▶** or **◀** to move the cursor right and left.
- 8 When the desired size is displayed, press **[OK]**.
- 9 Press **[Menu]**. The display returns to Ready.

### Character Pitch for Courier/Letter Gothic

You can set the character pitch for fixed fonts when the default font is Courier or Letter Gothic.

**1** Press **[Menu]**.

**2** Press **▲** or **▼** repeatedly until `Font >` appears.

```
Font >
```

**3** Press **▶**. Press **▲** or **▼** until `>Font Select >` appears.

```
>Font Select >
Internal
```

**4** Make sure that `Internal` is displayed and press **▷**.

**5** Press **▲** or **▼** repeatedly until `>>Pitch` appears.

```
>>Pitch
10.00 cpi
```

**6** Press **[OK]**. A blinking cursor (  ) appears.

```
>>Pitch
10.00 cpi
```

**7** Press **▲** or **▼** to increase or decrease the value at the blinking cursor. The character pitch can be set between 0.44 and 99.99 characters per inch, in 0.01 character-per-inch increments. Use **▶** or **◀** to move the cursor right and left.

**8** When the desired size is displayed, press **[OK]**.

**9** Press **[Menu]**. The display returns to `Ready`.

### Setting the Code Set

You can change the character code set. Available character code sets vary depending on the current font. (The default is `IBM PC-8`.)

**1** Press **[Menu]**.

**2** Press **▲** or **▼** repeatedly until `Font >` appears.

```
Font >
```

**3** Press **▶**.

- 4** Press **▲** or **▼** repeatedly until **>Code Set** appears.

```
>Code Set
  IBM PC-8
```

- 5** Press **[OK]**. A blinking question mark (?) appears.

```
>Code Set
?IBM PC-8
```

- 6** Press **▲** or **▼** until the desired character code set appears.

- 7** Press **[OK]**.

- 8** Press **[Menu]**. The display returns to *Ready*.

### Printing Lists of Fonts

To help you decide in selecting a font, you can printout lists of the internal fonts or the optional fonts including downloaded fonts.

- 1** Press **[Menu]**.

- 2** Press **▲** or **▼** repeatedly until **Font >** appears.

```
Font >
```

- 3** Press **▶**.

- 4** Press **▲** or **▼** repeatedly until **>List of Internal Fonts** or **>List of Option Fonts** appears.

```
>List of
  Internal Fonts
```

- 5** Press **[OK]**. A question mark (?) appears.

```
>List of
  Internal Fonts?
```

- 6** Press **[OK]** again. *Processing* appears, then *Ready*. The printer prints out a list of fonts with a sample and font ID (number) for each of them. Sample lists of fonts are shown in the following illustration.

### Samples of Fonts List

The image displays two overlapping screenshots of a software interface titled "Internal Scalable and Bitmapped Fonts List". Each screenshot features a "PRESCRIBE" button in the top right corner. The interface contains a table with the following columns: "Font Name", "Scalable/Bitmap", "Password", "Selection", "(FSET)", and "Font ID".

The top screenshot shows the beginning of the list, with the first few rows partially visible. The bottom screenshot shows the full list, which contains 30 rows of data. Each row in the list consists of a "Font Name" (e.g., "XXXXXXXXXX"), a "Scalable/Bitmap" status (e.g., "XXXXXX"), a "Password" (e.g., "XXXX"), a "Selection" status (e.g., "XXXXXXXXXXXX"), a "(FSET)" value (e.g., "XXXX"), and a "Font ID" (e.g., "XXXX").

## Pagination

In Page Set menus, you can set the number of copies, page orientation, and other settings regarding pagination.

### Number of Copies

You can set the number of copies of each page to be printed for the current interface. The number of copies can be set between 1 and 999.

**1** Press **[Menu]**.

**2** Press **▲** or **▼** repeatedly until Page Set > appears.

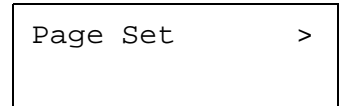

**3** Press **▶**.

**4** Press **▲** or **▼** repeatedly until >Copies appears.

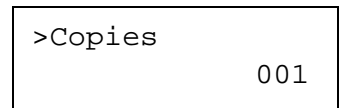

**5** Press **[OK]**. A blinking cursor (|) appears.



**6** Press **▲** or **▼** to increase or decrease, respectively, the value at the blinking cursor. Use **▶** and **◀** to move the cursor right and left.

**7** When the desired size is displayed, press **[OK]**.

**8** Press **[Menu]**. The display returns to Ready.

### Print Orientation

You can select portrait (upright) or landscape (sideways) page orientation.

Portrait Orientation

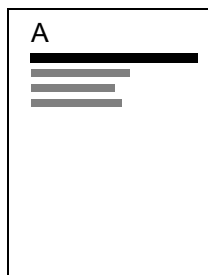

Landscape Orientation

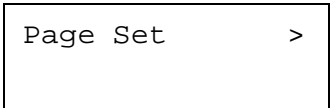
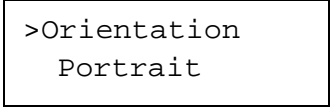
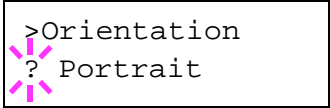

- 1 Press **[Menu]**.
- 2 Press **▲** or **▼** repeatedly until `Page Set >` appears. 
- 3 Press **▶**.
- 4 Press **▲** or **▼** repeatedly until `>Orientation` appears. 
- 5 Press **[OK]**. A blinking question mark (?) appears. 
- 6 Select `Portrait` or `Landscape` using **▲** or **▼**.
- 7 Press **[OK]**.
- 8 Press **[Menu]**. The display returns to `Ready`.

## Page Protect Mode

The Page Protect Menu does not normally appear, however, `Page Protect` will be forcibly set to `On` if a print overrun error occurs because the print job is too complex. When this has happened, be sure to reset `Page Protect` to `Auto` (default) in order to maintain the optimum use of printer memory.

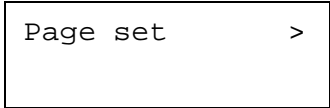
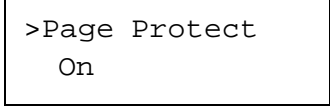
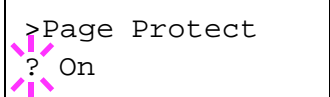
- 1 Press **[Menu]**.
- 2 Press **▲** or **▼** repeatedly until `Page set >` appears. 
- 3 Press **▶**.
- 4 Press **▲** or **▼** repeatedly until `>Page Protect` appears. 
- 5 Press **[OK]**. A blinking question mark (?) appears. 

- 6** Press **▲** or **▼** repeatedly until **Auto** appears.

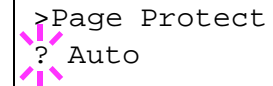

- 7** Press **[OK]**.

- 8** Press **[Menu]**. The display returns to **Ready**.

## Linefeed (LF) Action

This procedure instructs the printer what to do when it receives a linefeed code (0AH).

- **LF only**: Linefeed is performed (Default).
- **CR and LF**: A linefeed and carriage return are performed.
- **Ignore LF**: The linefeed is ignored.

- 1** Press **[Menu]**.

- 2** Press **▲** or **▼** repeatedly until **Page Set >** appears.

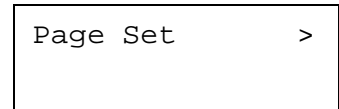

- 3** Press **▶**.

- 4** Press **▲** or **▼** repeatedly until **>LF Action** appears.

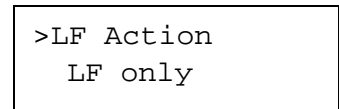

- 5** Press **[OK]**. A blinking question mark (?) appears.

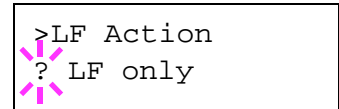

- 6** Press **▲** or **▼** repeatedly until the desired linefeed action appears.

- 7** When the desired action is displayed, press **[OK]**.

- 8** Press **[Menu]**. The display returns to **Ready**.

## Carriage-Return (CR) Action

This procedure instructs the printer what to do when it receives a carriage-return code (ODH).

- `CR only`: A carriage-return is performed (Default).
- `CR and LF`: A linefeed and carriage return are performed.
- `Ignore CR`: The carriage-return is ignored.

**1** Press **[Menu]**.

**2** Press **▲** or **▼** repeatedly until `Page Set >` appears.

A rectangular box representing the printer's display. It contains the text "Page Set" followed by a right-pointing chevron symbol "&gt;" on the same line.

**3** Press **▶**.

**4** Press **▲** or **▼** repeatedly until `>CR Action` appears.

A rectangular box representing the printer's display. It contains the text "&gt;CR Action" on the top line and "CR only" on the bottom line.

**5** Press **[OK]**. A blinking question mark (?) appears.

A rectangular box representing the printer's display. It contains the text "&gt;CR Action" on the top line and "? CR only" on the bottom line. The question mark is surrounded by a pink, starburst-like graphic.

**6** Press **▲** or **▼** repeatedly until the desired carriage-return action appears.

**7** When the desired action is displayed, press **[OK]**.

**8** Press **[Menu]**. The display returns to `Ready`.

## Wide A4 Pitch

Turn this to `On` to increase the maximum number of characters that can be printed in a line for an A4 page (78 characters at 10 pitch) and Letter size page (80 characters at 10 pitch). This setting is only effective in PCL 6 emulation.

**1** Press **[Menu]**.

**2** Press **▲** or **▼** repeatedly until `Page set >` appears.

A rectangular box representing the printer's display. It contains the text "Page Set" followed by a right-pointing chevron symbol "&gt;" on the same line.

**3** Press **▶**.

- 4** Press **▲** or **▼** repeatedly until **>Wide A4** appears.

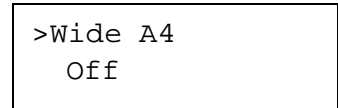

- 5** Press **[OK]**. A blinking question mark (?) appears.

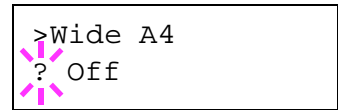

- 6** Select **On** or **Off** using **▲** or **▼**.

- 7** Press **[OK]**.

- 8** Press **[Menu]**. The display returns to **Ready**.

## Setting Print Quality

In Print Quality menus, you can set the KIR mode, EcoPrint mode, and other settings.

### KIR Mode

This printer incorporates the KIR (Kyocera Image Refinement) smoothing function. KIR uses the software to enhance resolution, resulting in high quality printing at resolution of 600 dpi and 300 dpi. The default is On. KIR has no effect on the printing speed.

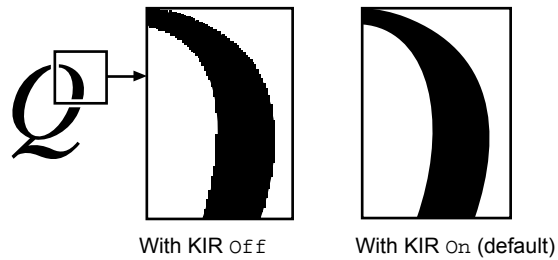

**NOTE:** Set the print density to 03 when setting the KIR mode. For details on the print density, refer to *Print Density on page 2-52*. You can monitor the KIR test pattern, the last line on a status page, to make the optimum KIR mode setting.

Look at the check line, the last line on a status page, to make the optimum KIR mode setting.

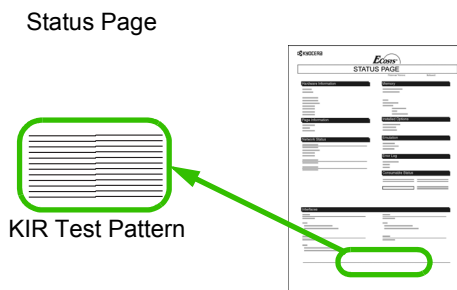

#### Optimized stripes

The current KIR setting is optimal.



#### Dark vertical stripes

Set the KIR mode to Off. Try printing the status page again. If you still get dark vertical stripes, adjust the print density control to a lighter setting.



#### White vertical stripes

Set the KIR mode to On. Try printing the status page again. If you still get white vertical stripes, adjust the print density control to a darker setting.



- 1 Press **[Menu]**.
- 2 Press **▲** or **▼** repeatedly until `Print Quality >` appears.
 

Print Quality >
- 3 Press **▶**.
- 4 Press **▲** or **▼** repeatedly until `>KIR Mode` appears.
 

>KIR Mode  
On
- 5 Press **[OK]**. A blinking question mark (?) appears.
 

>KIR Mode  
? On
- 6 Select `On` or `Off` using the **▲** or **▼**.
- 7 Press **[OK]**.
- 8 Press **[Menu]**. The display returns to `Ready`.

## EcoPrint Mode

The EcoPrint enables you to reduce the amount of toner consumed on the page so as to save your printing costs. You can set the EcoPrint mode to `On`, as follows. (The factory default setting is `Off`.) When the EcoPrint mode is set to `On`, the toner consumption is reduced and the print density becomes lighter. The EcoPrint setting has no effect on the print speed.



EcoPrint setting is  
Off (default)

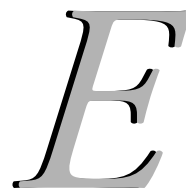

EcoPrint setting is  
On

- 1 Press **[Menu]**.
- 2 Press **▲** or **▼** repeatedly until `Print Quality >` appears.
 

Print Quality >
- 3 Press **▶**.

- 4** Press **▲** or **▼** repeatedly until **>EcoPrint Mode** appears.

```
>EcoPrint Mode
  Off
```

- 5** Press **[OK]**. A blinking question mark (?) appears.

```
>EcoPrint Mode
? Off
```

- 6** Select **On** or **Off** using the **▲** or **▼**.

- 7** Press **[OK]**.

- 8** Press **[Menu]**. The display returns to **Ready**.

## Print Resolution

You can set the default print resolution in four ways: 300dpi, 600dpi, Fast 1200 mode and Fine 1200 mode. The clarity of printed characters and graphics becomes sharper in this order.

- 1** Press **[Menu]**.

- 2** Press **▲** or **▼** repeatedly until **Print Quality >** appears.

```
Print Quality >
```

- 3** Press **▶**.

- 4** Press **▲** or **▼** repeatedly until **>Resolution** appears.

```
>Resolution
  Fast 1200 mode
```

- 5** Press **[OK]**. A blinking question mark (?) appears.

```
>Resolution
? Fast 1200 mode
```



- 6** Select **Fine 1200 mode**, **Fast 1200 mode**, **300 dpi** or **600 dpi** using the **▲** or **▼**.

- 7** Press **[OK]**.

- 8** Press **[Menu]**. The display returns to **Ready**.

## Print Density

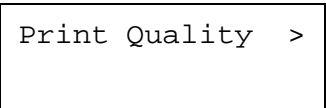
The print density can be adjusted in five steps: from 01 (light) to 05 (dark). The factory setting is 03.

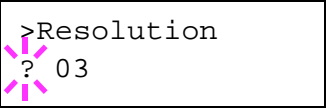
- 1 Press **[Menu]**.
- 2 Press **▲** or **▼** repeatedly until `Print Quality >` appears. 
- 3 Press **▶**.
- 4 Press **▲** or **▼** repeatedly until `>Print Density` appears. 
- 5 Press **[OK]**. A blinking question mark (?) appears. 
- 6 Select the print density from five steps from 01 (light) to 05 (dark) using the **▲** or **▼**.
- 7 Press **[OK]**.
- 8 Press **[Menu]**. The display returns to Ready.

## Operating the Storage Device

The printer supports four types of storage device; CompactFlash card, Microdrive, USB flash memory, and RAM disk. The CompactFlash card and Microdrive are installed into the dedicated slots of the printer. The RAM disk is an allocated part of the printer's memory. If the Microdrive is installed in the printer, the e-MPS function will be available. For details, refer to *e-MPS on page 2-19*.

The basic operations of each storage device are the same. This section explains the operation of the CompactFlash card.

### Using the CompactFlash Card

The printer is equipped with a slot for a CompactFlash card. By inserting a CompactFlash card into the printer, the following operations become available.

- Reading Font Data
- Reading Data
- Writing Data
- Deleting Data
- Formatting CompactFlash Card
- Printing a List of Data Names

For details about the handling of the memory card, refer to *Microdrive (Hard Disk)/CompactFlash (Memory) Card on page 3-6*.

#### Reading Font Data

If a CompactFlash card with the font data is inserted into the slot when the printer is turned on, the fonts are automatically read into the printer.

- 1** Press **[Menu]**.
- 2** Press **▲** or **▼** repeatedly until `Memory Card >` appears.
- 3** Press **▶**.
- 4** Press **▲** or **▼** repeatedly until `>Read Fonts` appears.
- 5** Press **[OK]**. A question mark (?) appears.

```
Memory Card >
```

```
>Read Fonts
```

```
>Read Fonts ?
```

- 6** Press **[OK]**. Processing appears and the reading of data from the CompactFlash card starts. When completed, Processing disappears.

```
>Read Fonts
Processing
```

- 7** Press **[Menu]**. The display returns to Ready.

### Reading Data

You can print out the data in the CompactFlash card.

- 1** Press **[Menu]**.

- 2** Press **▲** or **▼** repeatedly until Memory Card > appears.

```
Memory Card >
```

- 3** Press **▶**.

- 4** Press **▲** or **▼** repeatedly until >Read Data appears (Report, in this example).

```
>Read Data
Report
```

To read macro data or program data, press **▲** or **▼** to display >Read Macro or >Read Program.

- 5** Press **[OK]**. A blinking question mark (?) appears before the data name.

```
>Read Data
?Report
```

- 6** Press **▲** or **▼** to display the desired data name.

- 7** Press **[OK]**. Processing appears and the reading of data from the CompactFlash card starts.

### Writing Data

Data can be written to a CompactFlash card until the card is full. When writing to a CompactFlash card, a name is assigned to the file automatically. You can use the procedure explained in the section *Printing a List of Data Names (Partitions)* on page 2-59 to print a list of data names for confirmation.

---

**NOTE:** First check that the CompactFlash card is properly formatted. Otherwise, the >Write Data message to be explained below will not be shown on the message display. If the CompactFlash card inserted in the memory card slot is not formatted, >Format will automatically appear on the message display. Format the CompactFlash card. Refer to *Formatting a Memory Card* on page 2-58.

---

**1** Press **[Menu]**.

**2** Press **▲** or **▼** repeatedly until Memory Card > appears.

```
Memory Card  >
```

**3** Press **▶**.

**4** Press **▲** or **▼** repeatedly until >Write Data appears.

```
>Write Data
```

**5** Press **[OK]**. A question mark (?) appears.

```
>Write Data ?
```

**6** Press **[OK]**. Processing appears, then Waiting.

**7** Send the file from the computer to the printer.

As the printer receives data, the message display changes to Processing, then when the end of the data is received, the message display changes to Waiting.

**8** Check that the message display has changed to Waiting, then press **[GO]**. This writes the file to the CompactFlash card and instructs the printer to automatically print out a CompactFlash card write information page as shown below.

The file is written onto the CompactFlash card given a destination name (also referred to as a partition name) which the printer automatically

assigns one after another as follows: DataS001 (first data), DataS002 (second data), DataS003 (third data)...

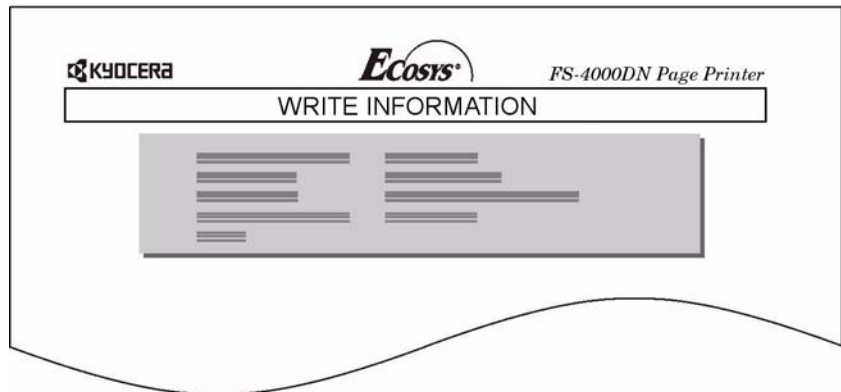

The write information page includes the following items:

Item	Description
<b>Partition Type</b>	Type of data written (currently only type 2 is supported).
<b>Partition Name</b>	The destination name of data written to the CompactFlash card.
<b>Write Partition Length</b>	The size of the written data on the CompactFlash card.
<b>Others</b>	Error information.

When the CompactFlash card write information page is printed, the display returns to *Ready*.

- 9 Repeat above steps until you have transferred all data (files) that you want to write to the CompactFlash card. Each time you finish writing data, a CompactFlash card write information page is printed from the printer showing the information, but pertaining only to the data just written. To see all data contained in the CompactFlash card at once, print a list of data names as explained. Refer to *Printing a List of Data Names (Partitions)* on page 2-59.

### Deleting Data

It is possible to use the printer to delete data from a CompactFlash card.

Check that the CompactFlash card contains data. Otherwise, the `>Delete Data` menu will not appear on the message display.

- 1 Press **[Menu]**.
- 2 Press **▲** or **▼** repeatedly until `Memory Card >` appears.

Memory Card >

**3** Press **▶**.

**4** Press **▲** or **▼** repeatedly until **>Delete Data** appears. The data name also appears (**Report**, in this example).

```
>Delete Data
  Report
```

To delete font data, program data, macro data or language data, press **▲** or **▼** to display **>Delete Font**, **>Delete Program**, **>Delete Macro** or **>Delete Language**.

**5** Press **[OK]**. A blinking question mark (?) appears before the data name.

```
>Delete Data
?Report
```

**6** Press **▲** or **▼** to display the desired data name.

**7** Press **[OK]**. Processing appears and the data is deleted from the CompactFlash card. The display returns to **Ready**.

### Formatting a Memory Card

A new CompactFlash card must be formatted before it can be used in the printer. Formatting allows data to be written to the CompactFlash card.

**NOTE:** Formatting will destroy any existing data on a storage device including a used CompactFlash card. Formatting of the CompactFlash card must be executed from the printer.

When a new CompactFlash card is inserted in the memory card slot, **Format error Memory card** will appear on the message display.

**1** Press **[Menu]**.

**2** Press **▲** or **▼** repeatedly until **Memory Card >** appears.

```
Memory Card >
```

**3** Press **▶**.

**4** Press **▲** or **▼** repeatedly until **>Format** appears.

```
>Format
```

**5** Press **[OK]**. A question mark (?) appears.

```
>Format ?
```

**6** Press **[OK]**. Processing appears and formatting of the CompactFlash card starts.

When the formatting is successfully completed, the printer automatically prints out a format information page, which allows you to check the CompactFlash card for proper formatting.

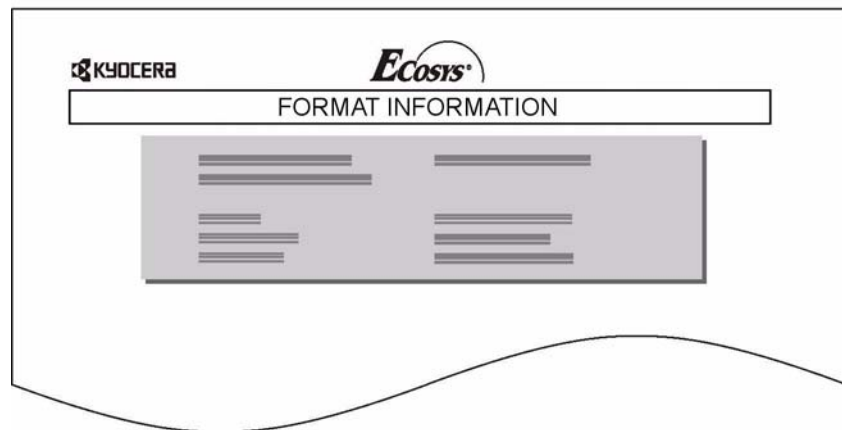

Format information page includes the following items:

Item	Description
<b>Capacity</b>	The total size of the CompactFlash card.
<b>Used Space</b>	The size the printer uses for its system.
<b>Free Space</b>	The size remaining in the CompactFlash card for storing data.

When the CompactFlash card format information is printed, the display returns to Ready.

### Printing a List of Data Names (Partitions)

The printer prints a list of all data names (referred to as partitions) stored in a CompactFlash card for reference. (Printing a list is also available for a font card.)

- 1** Press **[Menu]**.
- 2** Press **▲** or **▼** repeatedly until Memory Card > appears.
- 3** Press **▶**.
- 4** Press **▲** or **▼** repeatedly until >List of Partitions appears.

```
Memory Card  >
```

```
>List of
Partitions
```

- 5 Press [OK]. A question mark (?) appears.

>List of  
Partitions ?

- 6 Press [OK]. Processing appears and the printing of the list starts.

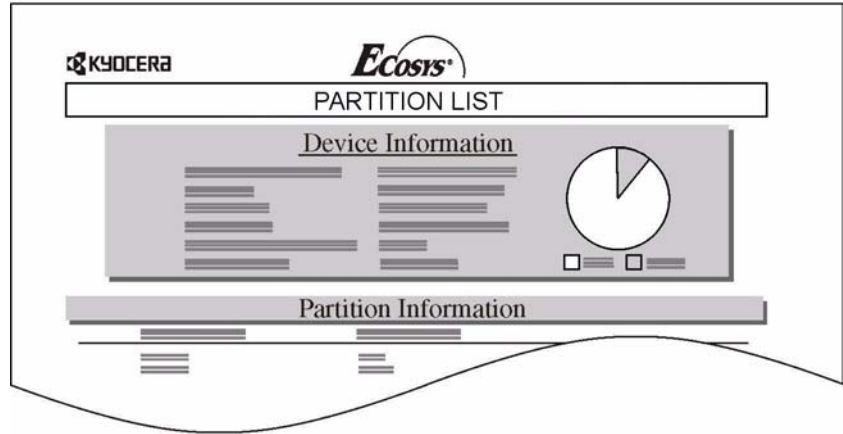

The printout (example above) includes the following information:

Item	Description
<b>Device Name/Number</b>	MEMORY CARD/A is indicated for the CompactFlash card.
<b>Capacity</b>	The total capacity of the CompactFlash card in kilobytes.
<b>Used Space</b>	The total size of the data stored in the CompactFlash card in kilobytes.
<b>Free Space</b>	The size of the capacity remaining in the CompactFlash card for storing further data, including the amount of memory that the printer uses for its system.
<b>Partition Name</b>	The name of the written data assigned automatically by the printer.
<b>Partition Size</b>	The size of the written data in bytes.
<b>Partition Type</b>	The type of the written data i.e., whether it is host data (Data) or font data (Font).

When the list of file names (partition list) for the CompactFlash card is printed, the display returns to *Ready*.

## Using the Microdrive

Installing the optional Microdrive into the printer allows you to perform the following operations on the Microdrive.

- Reading data
- Writing data
- Deleting data
- Formatting Microdrive
- Printing a list of data names (partitions)

When an Microdrive is inserted into the printer for the first time, it must be formatted before use. If the Microdrive is not formatted, the `>Format` menu will automatically appear on the display.

The operations of the Microdrive are the same as those of the memory card. Refer to the relevant sections in *Using the CompactFlash Card* on page 2-54.

When data is written to the hard disk, the name automatically given to the corresponding file will be DataH001 (for the 1st file), DataH002 (for the 2nd file), DataH003 (for the 3rd file), etc.

## Using the RAM Disk

The RAM disk is a memory space shared within the printer memory that can temporarily store print jobs. The stored print job can then be used to print multiple copies of the job reducing the total amount of time required to print the whole job. It acts similar to the Microdrive except that the data is effective only when the printer is powered up.

To use the RAM disk, activate and enter the desired size of the RAM disk in the manner described below. The maximum RAM disk size can be calculated as follows:

Maximum RAM disk size = Total printer memory -36MB

For example, if the total memory installed in your printer is 192MB, you can set 156MB of RAM disk. If you attempt to set the RAM disk size beyond this restriction, the printer automatically rounds it down so that the size is always 36MB less than the total printer memory. Once the RAM disk size is set, the printer must be reset.

To activate RAM disk in the printer's memory, first you must set the RAM disk mode to On and set the desired data size for the RAM disk as described in the following section. This allows you to perform the following operations on the RAM disk.

- Reading data
- Writing data
- Deleting data
- Printing a list of data names (partitions)

The operations of the RAM disk are the same as those of the CompactFlash card. Refer to the relevant sections in *Using the CompactFlash Card* on page 2-54. When data is written to the RAM disk, the name automatically given to the corresponding file will be DataH001 (for the 1st file), DataH002 (for the 2nd file), DataH003 (for the 3rd file), etc.

**NOTE:** The RAM disk can not be used when a Microdrive is installed. The RAM disk stores data only temporarily. When the printer is reset or turned off, the stored data will be erased. The RAM disk is allocated within the printer's memory available to users. If the size of the RAM disk is set too large, the printing speed may decrease or the memory may become insufficient.

### Setting the RAM Disk Size

**1** Press **[Menu]**.

**2** Press **▲** or **▼** repeatedly until RAM Disk Mode> appears.

```
RAM Disk Mode
Off
```

**3** Press **[OK]**. A blinking question mark (?) appears. Press **▲** or **▼** to select On. Press **[OK]**.

```
RAM Disk Mode
? On
```

**4** Press **▶**. Press **▲** or **▼** repeatedly until >RAM Disk Size appears. The data size also appears.

```
>RAM Disk Size
0156 MByte
```

**5** Press **[OK]**. A blinking cursor (    ) appears. Press **▲** or **▼** to display the desired size. Definable RAM disk size is 0001 to 1024.

```
>RAM Disk Size
0156 MByte
```

This range varies depending on the total memory size of the printer. The setting exceeding this range is automatically adjusted to the maximum RAM disk size.

**6** When the desired RAM disk size is displayed, press **[OK]**.

**7** Press **[Menu]**. The display returns to Ready. Turn the printer off and then on again. The selected RAM disk size is activated after the printer is restarted.

## Using USB Flash Memory

The USB flash memory is available for only PDF file. PDF files should be stored on the root directory of USB flash memory. The PDF file name can be up to 99 single-byte characters in length.

**NOTE:** The file name which is displayed on the message display can be up to 16 characters.

Installing the USB flash memory into the printer allows you to perform the following operations.

- Reading PDF file
- Removing the USB flash memory
- Printing a list of data names (partitions)

The operations of the USB flash memory are the same as those of the CompactFlash card. Refer to the relevant sections in *Using the CompactFlash Card* on page 2-54.

### Removing the USB Flash Memory

**1** Press **[Menu]**.

**2** Press **▲** or **▼** repeatedly until USB memory > appears.

```
USB Memory >
```

**3** Press **▶**.

**4** Press **▲** or **▼** repeatedly until >Remove Device appears.

```
>Remove Device
```

**5** Press **[OK]**. A question mark (?) appears.

```
>Remove Device ?
```

**6** Press **[OK]**. The display returns to Ready, and you can remove the USB flash memory.

## Paper Handling

This section explains how to change mode for the MP tray, the paper size and type for each paper source, and how to select the paper source and paper destinations.

### MP Tray Mode

The MP tray can be used in either of two modes — *Cassette* or *First*. The MP tray feed paper differently depending on the mode:

- **Cassette Mode (default)**  
The MP tray acts in the same manner as other paper sources. The printer can feed paper from any paper source you command on the printer driver. The cassette mode provides a faster printing speed than the first mode.
- **First Mode**  
The MP tray automatically feeds paper placed on the MP tray overriding another paper source that is selected on the printer driver. After all sheets in the MP tray have been used up (approximately 100 sheets), paper will be fed from the paper source originally selected. This mode is convenient to feed paper of special size or type without reloading the current paper source. However, the MP tray must be kept empty if you desire to feed paper from the intended paper source.

**1** Press **[Menu]**.

**2** Press **▲** or **▼** repeatedly until *Paper Handling >* appears.

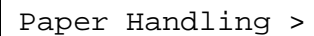

Paper Handling >

**3** Press **▶**.

**4** Press **▲** or **▼** repeatedly until *>MP Tray Mode* appears.

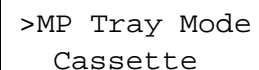

>MP Tray Mode  
Cassette

**5** Press **[OK]**. A blinking question mark (?) appears.

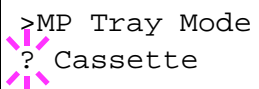

>MP Tray Mode  
? Cassette

**6** Press **▲** or **▼** to change *Cassette* to *First*.

**7** Press **[OK]**. The MP tray mode is changed.

**8** To exit the menu selection, press **[Menu]**.

## Setting MP Tray Paper Size

When you use the MP tray in cassette mode, you should set the MP tray size to the paper size that is used to format the job to print. If the sizes do not match, printing will not be performed on the correct size paper. The default setting is Letter size for the U.S. and Canada and A4 for other countries. For more information about the paper sizes that you can feed from the MP tray, refer to *Paper Specifications on page 1-2*.

**NOTE:** Feeding the paper having a paper size which does not match the current paper size from the MP tray can cause paper jam.

**1** Press **[Menu]**.

**2** Press **▲** or **▼** repeatedly until Paper Handling > appears.

```
Paper Handling >
```

**3** Press **▶**.

**4** Press **▲** or **▼** repeatedly until >MP Tray Size appears. In this example, the current MP tray paper size is A4.

```
>MP Tray Size
A4
```

**5** To change the paper size, press **[OK]**. A blinking question mark (?) appears.

**6** Press **▲** or **▼** to display the desired paper size. The message display toggles through the following paper sizes:

```
Letter
Legal
Custom
Oficio II
Statement
Folio
Youkei 2
Youkei 4
16K
Hagaki
OufukuHagaki
Env. Monarch
Envelope #10
Envelope #9
Envelope #6
Envelope DL
Envelope C5
A6
B6
A5
B5
```

ISO B5  
A4  
Executive

- 7 When the desired paper size is displayed, press **[OK]**. The paper size is set for the MP tray.
- 8 To exit the menu selection, press **[Menu]**.

## Setting the MP Tray Paper Type

By setting a paper type (plain, recycled, etc.) for the MP tray, you can select the paper on the MP tray according to the paper type you command on the printer driver. The default setting is plain paper.

For more information about paper types that can be fed from the MP tray, refer to *Paper Availability on page 1-2*.

- 1 Press **[Menu]**.
- 2 Press **▲** or **▼** repeatedly until Paper Handling > appears.
- 3 Press **▶**.
- 4 Press **▲** or **▼** repeatedly until >MP Tray Type appears.

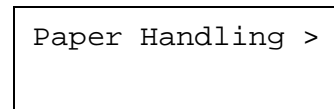

Paper Handling >

- 5 To change paper type, press **[OK]**. A blinking question mark (?) appears.

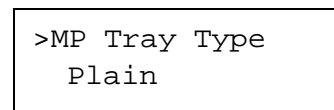

>MP Tray Type  
Plain

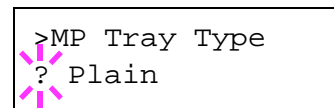

>MP Tray Type  
? Plain

- 6 Press **▲** or **▼** to display the desired paper type. The message display toggles through the following paper types:

Plain  
Transparency  
Preprinted  
Labels  
Bond  
Recycled  
Vellum  
Rough  
Letterhead  
Color  
Prepunched  
Envelope  
Cardstock  
Thick

High quality  
Custom 1(to 8)

- 7 When the desired paper type is displayed, press **[OK]**. The paper type is set to the MP tray.
- 8 To exit the menu selection, press **[Menu]**.

## Setting the Cassette Paper Size

To set the standard sizes A6 (excl. FS-2000D), A5, B5, A4, Letter, and Legal size for the paper cassette, load the paper and turn the paper size dial so that the size of the paper you are going to use appears in the paper size window (refer to *Loading Paper on page 1-13*).

### Custom paper size

If you use a non-standard size paper, load the paper and turn the paper size dial to **OTHER** (refer to *Loading Paper on page 1-13*).

- 1 Press **[Menu]**.
- 2 Press **▲** or **▼** repeatedly until Paper Handling > appears.
- 3 Press **▶**.
- 4 Press **▲** or **▼** repeatedly until >Cassette Size > appears.

Paper Handling >

If optional paper feeders are added, Cassette 1 Size will appear for the standard paper cassette and Cassette 2 Size, Cassette 3 Size (FS-3900DN/FS-4000DN), and Cassette 4 size (FS-3900DN/FS-4000DN) will appear for the optional paper feeders.

>Cassette Size >  
Custom

- 5 Press **[OK]**. A blinking question mark (?) appears.

>Cassette Size  
? Custom

- 6 Press **▲** or **▼** to display the desired paper size. The message display toggles through the following paper sizes:

Custom  
Oficio II  
Folio  
16K  
Envelope C5  
A5  
A6 (FS-3900DN/FS-4000DN only)  
B5  
ISO B5

- A4
- Executive
- Letter
- Legal

**7** When the desired paper size is displayed, press **[OK]**. The paper size is set for the paper cassette.

If you selected *Custom* in step 6, be sure to set the unit of measurement and the dimensions of the paper as described in the following sections.

---

**NOTE:** When you set paper size for the optional feeder, A6 does not appear.

---

### Selecting the Unit of Measurement

**1** Press **▶**.

**2** Press **▲** or **▼** repeatedly until **>>Unit** appears. The unit of measurement can be selected between millimeters and inches. The current unit of measurement is displayed.

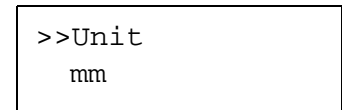

**3** Press **[OK]**. A blinking question mark (?) appears.

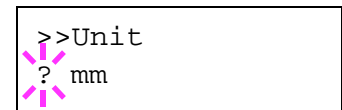

**4** Select **mm** or **inch** using **▲** or **▼**.







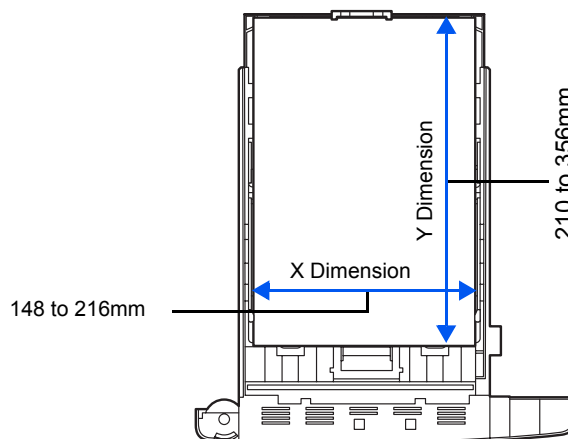

**5** Press **[OK]**.

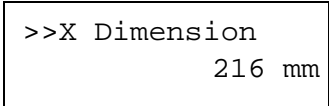
Set the dimensions of the paper as described in the next section.

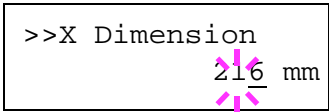
### Entering the Width and Length

**1** Enter the paper size for **X Dimension** and **Y Dimension** as shown in the figure.









- 2 When the unit of measurement is set, press . >>X Dimension appears (the paper width setting). 
- 3 Press **[OK]**. A blinking cursor (  ) appears. 
- 4 Press  or  to increase or decrease the value of the figure where the cursor is blinking and display the desired width. The width can be set between 148 and 216mm. You can use  or  to move the cursor right and left.
- 5 Display the paper width and press **[OK]**.
- 6 When the width is set, press . >>Y Dimension appears (the paper length setting). Set the desired length in the same way as the width. The length can be set between 210 and 356mm.
- 7 Display the paper length, press **[OK]**.
- 8 Press **[Menu]**. The display returns to Ready.
- 9 To print using the custom size set above, define the same custom size on the printer driver.

## Setting the Cassette Paper Type

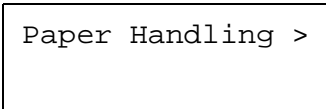
By setting a paper type (plain, recycled, etc.) for the paper cassette, you can automatically select the paper in the paper cassette according to the paper type you command on the printer driver. The default setting is plain paper for all paper cassettes.

For more information about paper types that you can feed from the paper cassette, refer to *Paper Specifications on page 1-2*.

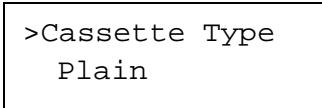
- 1 Press **[Menu]**.
- 2 Press  or  repeatedly until Paper Handling > appears. 
- 3 Press .
- 4 Press  or  repeatedly until >Cassette Type appears. 

If optional paper feeders are added, Cassette 1 Type will appear for the standard paper cassette and Cassette 2 Type, Cassette 3 Type

(FS-3900DN/FS-4000DN), and Cassette 4 Type (FS-3900DN/FS-4000DN) will appear for the optional paper feeders.

- 5 Press **[OK]**. A blinking question mark (?) appears.

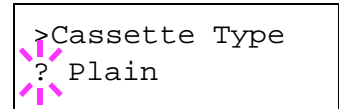

- 6 Press **▲** or **▼** to display the desired paper type. The message display toggles through the following paper types:

Plain  
 Preprinted  
 Bond  
 Recycled  
 Rough  
 Letterhead  
 Color  
 Prepunched  
 High quality  
 Custom 1 (to 8)

- 7 When the desired cassette type is displayed, press **[OK]**.
- 8 To exit the menu selection, press **[Menu]**.

### Selecting the Paper Feed Source

You can select the paper source, from which the printer feeds paper as the default. If an optional paper feeder(s) is installed, it is also available for the default paper source.

- 1 Press **[Menu]**.
- 2 Press **▲** or **▼** repeatedly until Paper Handling > appears.

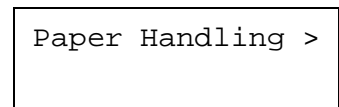

- 3 Press **▼**.
- 4 Press **▲** or **▼** repeatedly until >Feed Select appears.

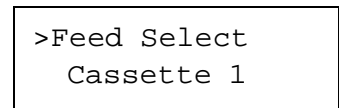

- 5 To change the current paper feed source, press **[OK]**. A blinking question mark (?) appears.

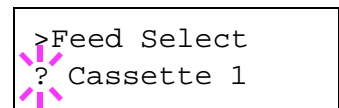

- 6 Press **▲** or **▼** to display the desired paper feed source. The message display toggles through the following paper feed sources, depending on

the installed optional paper feeders (from the top most paper cassette to the bottom paper cassette):

MP tray  
Cassette 1  
Cassette 2  
Cassette 3 (FS-3900DN/FS-4000DN only)  
Cassette 4 (FS-3900DN/FS-4000DN only)

- 7** When the desired paper source is displayed, press **[OK]**.
- 8** To exit the menu selection, press **[Menu]**.

## Duplex Printing

You can automatically print on both sides of the paper.

Duplex printing is available for the following paper types:

Plain  
Preprinted  
Bond  
Recycled  
Rough  
Letterhead  
Color  
Prepunched  
High quality  
Custom 1 (to 8)

Activating the duplexer is done by selecting either short edge or long edge binding mode.

---

**NOTE:** Duplex printing can be also performed from the MP tray. When the MP tray is set to First Mode (First), the paper size and paper type will be the same as those of the paper cassette currently set at the paper feed source. If the paper to be fed from the MP tray does not match the paper size and paper type of the current paper feed source cassette, a paper jam may occur.

---

## Binding Modes

Binding refers to the manner in which printed pages of paper are joined together (by gluing, stitching, etc.) in book form. The two possible types of binding are: long-edge binding, in which pages are joined together along their long edge; and short-edge binding, in which they are joined together along their short edge. In selecting a binding type, you must also consider the orientation of the printed page. You can use long-edge or short-edge binding with either landscape or portrait printing.

Depending on the binding type and print orientation, the duplexer provides four types of binding.

Portrait, long-edge

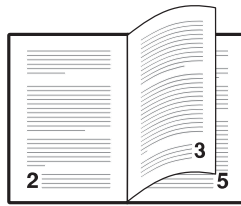

Portrait, short-edge

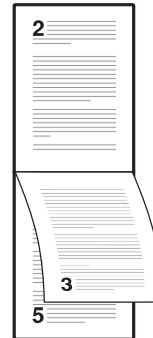

Landscape, long-edge

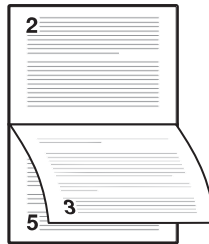

Landscape, short-edge



- 1 Press **[Menu]**.
- 2 Press **▲** or **▼** repeatedly until Paper Handling > appears.
- 3 Press **▼**.
- 4 Press **▲** or **▼** repeatedly until >Duplex Mode appears.
- 5 To activate duplex printing, press **[OK]**. A blinking question mark (?) appears.
- 6 Press **▲** or **▼** to display the desired binding mode. The message display toggles through the following:
  - Off (default)
  - Short edge bind
  - Long edge bind
- 7 When the desired binding mode is displayed, press **[OK]**. The binding mode is set.
- 8 To exit the menu selection, press **[Menu]**.

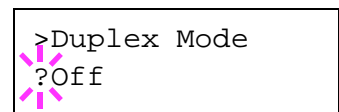
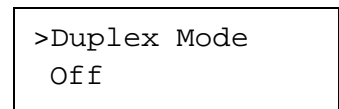
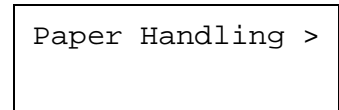

## Selecting the Output Stack (FS-3900DN/FS-4000DN)

The Stack Select menu on the operation panel allows you to select either the face-down tray or the faceup tray option for the output stack.

- 1 Press **[Menu]**.
- 2 Press **▲** or **▼** repeatedly until Paper Handling > appears.
 

Paper Handling >
- 3 Press **▶**.
- 4 Press **▲** or **▼** repeatedly until >Stack Select appears.
 

>Stack Select  
Top tray FaceDn
- 5 To change the output stack, press **[OK]**. A blinking question mark (?) appears.
 

>Stack Select  
?Top tray FaceDn
- 6 Press **▲** or **▼** select output stack - Top tray FaceDn or RearTray FaceUp.
- 7 When the desired output stack is displayed, press **[OK]**.

## Overriding Difference between A4 and Letter

When the Override A4/LT is turned On using the operation panel, the printer ignores the difference between A4 and Letter paper sizes. Printing is performed without an error message even if the actual paper size in the current cassette differs from the paper size formatting the job.

By default, this feature is off.

- 1 Press **[Menu]**.
- 2 Press **▲** or **▼** repeatedly until Paper Handling > appears.
 

Paper Handling >
- 3 Press **▶**.
- 4 Press **▲** or **▼** repeatedly until >Override A4/LT appears.
 

>Override A4/LT  
Off

- 5 To change overriding mode, press **[OK]**. A blinking question mark (?) appears.
- 6 Press **▲** or **▼** to change Off to On.
- 7 Press **[OK]**. The overriding mode is set.
- 8 To exit the menu selection, press **[Menu]**.

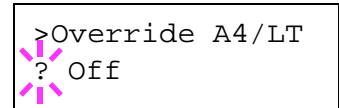

## Creating Custom Paper Type

The following describes the procedure used to set a user-defined paper type for the printer. Eight custom user settings may be registered. After having been set, any of these may be called up when setting the paper type for a paper source.

The paper weight and duplex path can be set (refer to *Setting the Paper Weight on page 2-75*, and *Setting the Duplex Path on page 2-75*) after selecting the paper type to be customized as follows. For how to reset the customized settings, refer to *Resetting the Custom Paper Type on page 2-76*.

- 1 Press **[Menu]**.
- 2 Press **▲** or **▼** repeatedly until Paper Handling > appears.
- 3 Press **▶**.
- 4 Press **▲** or **▼** repeatedly until >Type Adjust > appears.
- 5 Press **[OK]**. A blinking question mark (?) appears.

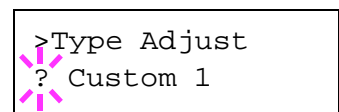
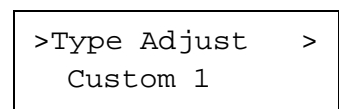
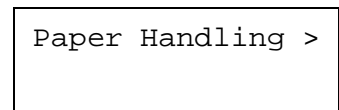

- 6 Press **▲** or **▼** to display the desired paper type. The display changes as shown below.

Custom 1 (to 8)  
 Plain  
 Transparency  
 Preprinted  
 Labels  
 Bond  
 Recycled  
 Vellum

Rough  
 Letterhead  
 Color  
 Prepunched  
 Envelope  
 Cardstock  
 Thick  
 High quality

- 7 When the paper type to be customized is displayed, press **[OK]**.
- 8 Press **▶** and proceed to Setting the Paper Weight.

### Setting the Paper Weight

You can set the paper thickness for your custom paper type to be customized.

- 1 Display the custom paper type (refer to *Creating Custom Paper Type on page 2-74*) and press **▶**.

- 2 Press **▲** or **▼** repeatedly until **>>Paper Weight** appears.

```
>>Paper Weight
Normal 2
```

- 3 Press **[OK]**. A blinking question mark (?) appears.

```
>>Paper Weight
? Normal 2
```

- 4 Press **▲** or **▼** to display the desired paper thickness. The display changes as shown below. For details of the default setting for each paper type, refer to *Paper Availability on page 1-2*.

Light  
 Normal 1  
 Normal 2  
 Normal 3  
 Heavy 1  
 Heavy 2  
 Heavy 3  
 Extra Heavy

- 5 When the desired paper thickness is displayed, press **[OK]** and proceed to *Setting the Duplex Path on page 2-75*.

### Setting the Duplex Path

You can set whether or not to enable duplex printing as follows. The default setting is **Enable**.

- 1 Display the custom paper type (refer to *Creating Custom Paper Type on page 2-74*) and press **▶**.

- 2** Press **▲** or **▼** repeatedly until **>>Duplex path** appears.

>>Duplex path  
Enable
- 3** Press **[OK]**. A blinking question mark (?) appears.

>>Duplex path  
? Enable
- 4** Select **Enable** or **Disable** using **▲** or **▼**. For details of the default setting for each paper type, refer to *Paper Availability on page 1-2*.
- 5** Press **[OK]**.
- 6** Press **[Menu]**. The display returns to **Ready**.  
The custom paper type setting is completed.

### Resetting the Custom Paper Type

- 1** Press **[Menu]**.
- 2** Press **▲** or **▼** repeatedly until **Paper Handling >** appears.

Paper Handling >
- 3** Press **▶**.
- 4** Press **▲** or **▼** repeatedly until **>Reset Type Adjust** appears.

>Reset Type  
Adjust
- 5** To reset all custom paper types, press **[OK]**. A question mark (?) appears.

>Reset Type  
Adjust ?
- 6** Press **[OK]**. All customized paper types will be reset to the default. The display returns to **Ready**.

## Reading Life Counters

You can display the total number of pages printed by your printer whenever it is necessary. The total number of printed pages can also be checked on the status page. Refer to *Printing a Status Page on page 2-15*.

### Displaying the Total Printed Pages

This procedure displays the total number of printed pages. You cannot change the displayed value.

- 1 Press **[Menu]**.
- 2 Press **▲** or **▼** repeatedly until `Life Counters >` appears.
- 3 Press **▶**.
- 4 Press **▲** or **▼** repeatedly until `>Printed Pages` appears and the latest total print count is shown.
- 5 To exit the menu selection, press **[Menu]**.

```
Life Counters >
```

```
>Printed Pages  
0123456
```

## Other Modes

The following modes can be accessed in the `Others` submenu:

- Message Language
- Automatic Form Feed Timeout Setting
- Sleep Timer Setting
- Received Data Dumping
- Printer Resetting
- Resource Setting
- Alarm (Buzzer) Setting
- Auto Error Clear Setting
- Duplex Printing Error Detection Setting
- Service Menu (for service technician)

### Selecting the Message Language

You can select the language of the message display by following the procedure given below. You can optionally download messages in other languages. Contact your service technician for information.

**1** Press **[Menu]**.

**2** Press **▲** or **▼** repeatedly until `Others >` appears.

```
Others >
```

**3** Press **▶**.

**4** Press **▲** or **▼** repeatedly until `>MSG Language` appears. The default message language is `English`.

```
>MSG Language  
English
```

**5** To change the language, press **[OK]**. A blinking question mark (?) appears.

```
>MSG Language  
? English
```

**6** Press **▲** or **▼**. The display cycles through the available selection in the following order:

```
English  
Francais  
Deutsch  
Italiano  
Nederlands  
Español  
Português
```

- 7 Press **[OK]**.
- 8 Press **[Menu]**. The display returns to Ready.

## Automatic Form Feed Timeout Setting

If the printer receives no data for a certain period, it will time out and release the current interface. It prints whatever data it has in its buffer and feeds out the page. The default form feed timeout time is 30 seconds.

- 1 Press **[Menu]**.
- 2 Press **▲** or **▼** repeatedly until Others > appears.
 

Others >
- 3 Press **▶**.
- 4 Press **▲** or **▼** repeatedly until >Form Feed Time Out appears.
 

>Form Feed  
Time Out 030sec.
- 5 To change the timeout time, press **[OK]**. A blinking cursor (|) appears.
 

>Form Feed  
Time Out 030|sec.
- 6 Press **▲** or **▼** to increase or decrease the value at the blinking cursor and set the desired time. The timeout time can be between 0 and 495 seconds, in 5-second increments. Use **▶** and **◀** to move the cursor right and left.
- 7 When the desired timeout time is displayed, press **[OK]**.
- 8 To exit the menu selection, press **[Menu]**.

## Setting the Sleep Timer

The printer has a sleep timer that is used to conserve power when the printer is not printing, processing, or receiving data.

- 1 Press **[Menu]**.
- 2 Press **▲** or **▼** repeatedly until Others > appears.
 

Others >
- 3 Press **▶**.

- 4** Press **▲** or **▼** repeatedly until **>Sleep Timer >** appears.

>Sleep Timer >  
015 min.
- 5** Press **▶** and display **>>Auto Sleep**.

>>Auto Sleep  
On
- 6** To set the sleep timer, press **[OK]**. A blinking question mark (?) appears.

>>Auto Sleep  
? On
- 7** Press **▲** or **▼** to change **On** to **Off**.

>>Auto Sleep  
? Off
- 8** Press **[OK]**. The sleep timer is turned off.
- 9** To exit the menu selection, press **[Menu]**.

### Sleep Timer Timeout Time

You can adjust the length of time the printer waits before entering Auto Sleep in the absence of data. The default time is 15 minutes.

The printer reverts to normal operation mode when the printer receives a print job, the operation panel is operated, or one of the exterior covers is opened.

- 1** Press **[Menu]**.
- 2** Press **▲** or **▼** repeatedly until **Others >** appears.

Others >
- 3** Press **▶**.
- 4** Press **▲** or **▼** repeatedly until **>Sleep Timer >** appears.

>Sleep Timer >  
015min.
- 5** To change the timeout time, press **[OK]**. A blinking cursor (|) appears.

>Sleep Timer  
015|min.

- 6 Press **▲** or **▼** to increase or decrease the value at the blinking cursor and set the desired time. The timer can be set between 5 and 240 min, in 5-minute increments. Use **▶** and **◀** to move the cursor right and left.
- 7 When the desired timeout time is displayed, press **[OK]**.
- 8 To exit the menu selection, press **[Menu]**.

## Received Data Dump

You can print data received by the printer as hexadecimal code for debugging programs and files.

- 1 Press **[Menu]**.
- 2 Press **▲** or **▼** repeatedly until `Others >` appears.
 

Others >
- 3 Press **▶**.
- 4 Press **▲** or **▼** repeatedly until `>Print HEX-DUMP` appears.
 

>Print HEX-DUMP
- 5 Press **[OK]**. A question mark (?) appears.
 

>Print HEX-DUMP?
- 6 Press **[OK]** again. The message `Processing` appears for a second, followed by `Waiting`.
 

Processing

↓

Waiting
- 7 While the message display is indicating `waiting` (for 30 seconds by default), send data to be hex-dumped to the printer. The message display indicates `Processing` while the data is being received.
 

You can cancel printing of any more dump data by pressing **[GO]** and then **[Cancel]**.
- 8 Once all data has been received, the message `Waiting` will appear. Press **[GO]** to finish hex-dump printing.

## Printer Resetting

The procedure described below resets the printer's temporary conditions, such as the current page orientation, font, etc., set by commands to their default values. Downloaded fonts and macros are deleted from the printer's memory.

**1** Press **[Menu]**.

**2** Press **▲** or **▼** repeatedly until `Others >` appears.

```
Others >
```

**3** Press **▶**.

**4** Press **▲** or **▼** repeatedly until `>Restart Printer` appears.

```
>Restart  
Printer
```

**5** To reset the printer, press **[OK]**. A question mark (?) appears.

```
>Restart  
Printer ?
```

**6** Press **[OK]** again. `Self test` appears while the printer is resetting itself, followed by `Please wait` and then `Ready`.

```
Self test
```



```
Please wait
```



```
Ready
```

## Resource Protection

By default, when you switch from the PCL 6 emulation to another, all downloaded fonts and macros will be lost. Resource protection preserves these PCL resources in memory so that they remain intact even when you have switched back in PCL 6.

---

**NOTE:** Resource protection requires extra memory to store the downloaded fonts and macros. The total size of the printer memory recommended for using the resource protection option is affected by several factors. Refer to *Expansion Memory Modules on page 3-3*.

---

By default, resource protection is deactivated.

- 1 Press **[Menu]**.
- 2 Press **▲** or **▼** repeatedly until `Others >` appears.
 

Others >
- 3 Press **▶**.
- 4 Press **▲** or **▼** repeatedly until `>Resource Prot.` appears.
 

>Resource Prot.  
Permanent
- 5 Press **[OK]**. A blinking question mark (?) appears.
 

>Resource Prot.  
? Permanent
- 6 Press **▲** or **▼** to select `Permanent` or `Perm / Temp` (Permanent/Temporary) for resource protection.
- 7 When the desired resource protection is displayed, press **[OK]**.
- 8 To exit the menu selection, press **[Menu]**.

## Alarm (Buzzer) Setting

You can set an alarm sound in addition to the message displayed when the paper supply is exhausted, or when paper jamming occurs. This setting is useful, for example, when the printer is located some distance from the user.

The audio alarm is set to `On` when leaving the factory. If the alarm is set to `Off`, it will not sound.

- 1 Press **[Menu]**.
- 2 Press **▲** or **▼** repeatedly until `Others >` appears.
 

Others >
- 3 Press **▶**.
- 4 Press **▲** or **▼** repeatedly until `>Buzzer >` appears.
 

>Buzzer >
- 5 Press **▶**.

- 6** Press **▲** or **▼** to display the desired alarm. The display changes as shown below.

Error  
Ready  
Job End  
Key Confirm.

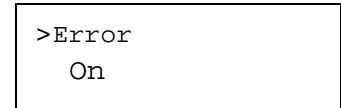

- 7** Press **[OK]**. A blinking question mark (?) appears.

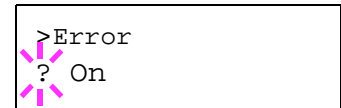

- 8** Select On or Off using **▲** or **▼**.

- 9** Press **[OK]**.

- 10** To exit the menu selection, press **[Menu]**.

## Auto Error Clear Setting

If an error that still allows you to continue printing occurs, the next received data is automatically printed after a set period of time elapses. For example, if the printer is shared over a network as a network printer and one person causes one of the following errors, after the set period of time elapses, the data sent from the next person is printed. The default setting is *Off* (Auto Error Clear disabled). The auto clear errors are:

- Memory overflow
- Print overrun
- KPDLE error
- File is not found
- RAM disk error
- CompactFlash card error
- Microdrive error
- Duplex printing is disabled
- e-MPS job is not stored
- Multiple copies are not printed
- Illegal account
- Exceeded Max. out
- Account error
- USB memory error

---

**NOTE:** For setting the auto error clear recovery time, refer to the next section.

---

- 1** Press **[Menu]**.

- 2 Press **▲** or **▼** repeatedly until Others > appears.
 

Others >
- 3 Press **▶**.
- 4 Press **▲** or **▼** repeatedly until >Auto Error Clear > appears.
 

>Auto Error >  
Clear Off
- 5 Press **[OK]**. A blinking question mark (?) appears.
 

>Auto Error  
Clear ? Off
- 6 Select On or Off using **▲** or **▼**.
- 7 Press **[OK]**.
- 8 To exit the menu selection, press **[Menu]**. The display returns to Ready.

### Setting the Error Clear Time

- 1 Press **[Menu]**.
- 2 Press **▲** or **▼** repeatedly until Others > appears.
 

Others >
- 3 Press **▶**.
- 4 Press **▲** or **▼** repeatedly until >Auto Error Clear > appears.
 

>Auto Error >  
Clear On
- 5 Press **▶** and display >>Error Clear Timer. The default setting is 30 seconds.
 

>>Error Clear  
Timer 030sec.
- 6 Press **[OK]**. A blinking cursor ( ) appears.
 

>>Error Clear  
Timer 030sec.
- 7 Press **▲** or **▼** to increase or decrease the value at the blinking cursor and set the desired time. The time must be set between 000 and 495 seconds, in 5-second increments. If set to 000, printing will be continued

immediately without any time interval. You can use **▶** and **◀** to move the cursor right and left.

- 8** Display the desired time and press **[OK]**.
- 9** Press **[Menu]**. The display returns to Ready.

### Duplex Printing Error Detection Setting

If the error detection setting for duplex printing has been turned On, and you attempt to print onto a paper size and paper type that cannot be used for duplex printing, the Duplex disabled Press GO error message will be displayed and printing will stop. To print onto one-side of the paper only when this message is displayed, press **[GO]**. The default setting is Off.

- 1** Press **[Menu]**.
- 2** Press **▲** or **▼** repeatedly until Others > appears.

```
Others      >
```

- 3** Press **▶**.

- 4** Press **▲** or **▼** repeatedly until >Finishing Error > appears.

```
>Finishing >
Error
```

- 5** Press **▶** and display >>Duplex.

```
>>Duplex
Off
```

- 6** Press **[OK]**. A blinking question mark (?) appears.

```
>>Duplex
? Off
```

- 7** Press **▲** or **▼** to change Off to On.

```
>>Duplex
? On
```

- 8** Press **[OK]**.
- 9** To exit the menu selection, press **[Menu]**.

## Printing the Service Status Page

The service status page contains printer settings information that is more detailed than the standard status page and is therefore mostly for service purposes. However, there is a great deal of information on the service status page that may be useful to you.

**1** Press **[Menu]**.

**2** Press **▲** or **▼** repeatedly until `Others >` appears.

```
Others >
```

**3** Press **▶**.

**4** Press **▲** or **▼** repeatedly until `>Service >` appears.

```
>Service >
```

**5** Press **▶**.

**6** Press **▲** or **▼** repeatedly until `>>Print Status Page` appears.

```
>>Print  
Status Page
```

**7** Press **[OK]**. A question mark (?) appears.

```
>>Print  
Status Page ?
```

**8** Press **[OK]**. The display indicates `Processing` and printing starts.



# 3 Options

This chapter contains explanations on the following topics:

- General Information..... 3-2
- Expansion Memory Modules ..... 3-3
- General Description..... 3-6
- IB-21E/IB-30 Network Interface Cards ..... 3-8

For availability of the options, consult your service technician.

## General Information

The printers have the following options available to satisfy your printing requirements. For instructions on installing individual options, refer to the documentation included with the option. Some options are explained in the following sections.

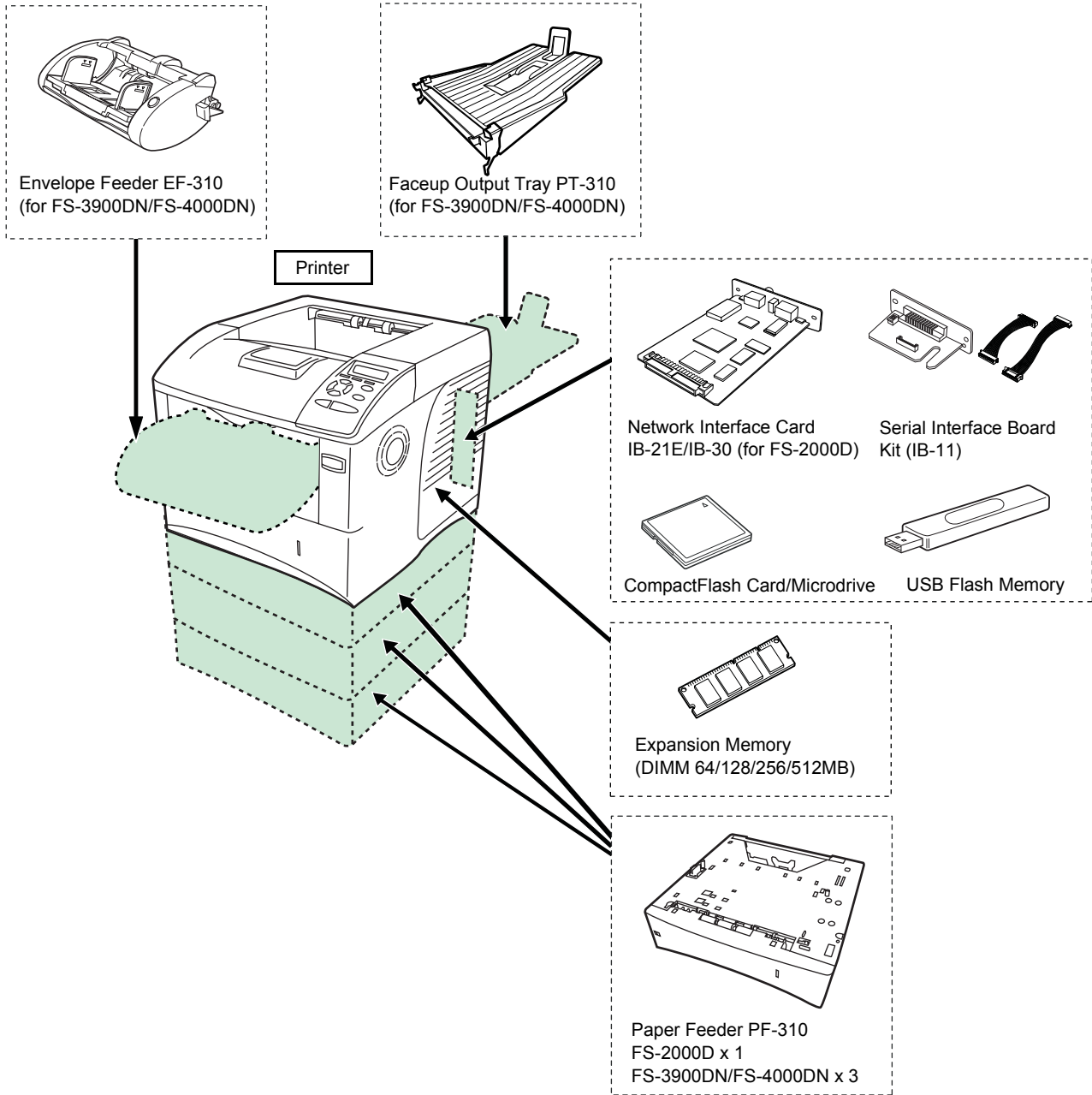

## Expansion Memory Modules

To expand the printer memory for more complex print jobs and faster print speed, you can plug in optional memory module (dual in line memory module) in the memory slot provided on the printer main controller board. You can select additional memory module from 64, 128, 256 or 512MB. The maximum memory size is 640MB (FS-2000D, FS-3900DN: 576MB).

**NOTE:** The expansion memory should only be installed by your service technician. We shall not be liable for any damages caused by improper installation of expansion memory.

Precautions for handling the printer's main controller board and memory module.

To protect electronic parts, discharge static electricity from your body by touching a water pipe (faucet) or other large metal object before handling the memory module. Or, wear an antistatic wrist strap, if possible, when you install the memory module.

Always hold the main controller board or a memory module by its edges as shown below to avoid damaging electronic parts.

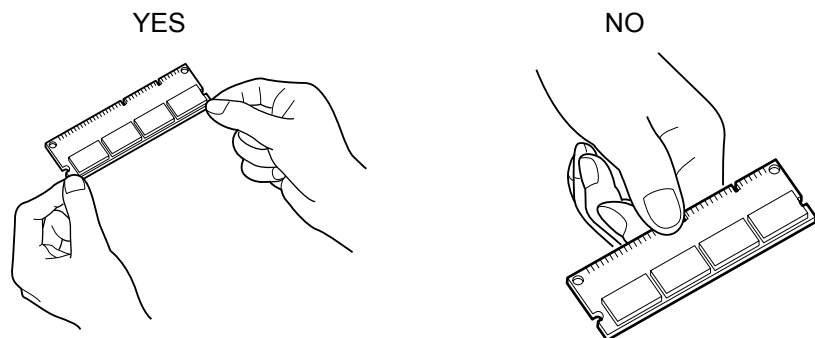

### Installing the Memory Module

- 1 Power off the printer and unplug the printer power cord.
- 2 Open the right cover and inner cover.

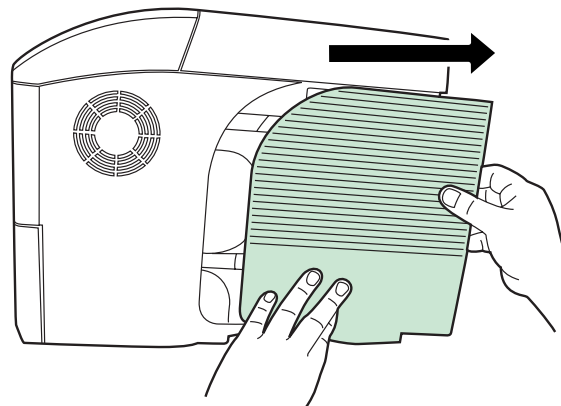

- 3** Remove the screw and open the inner cover.

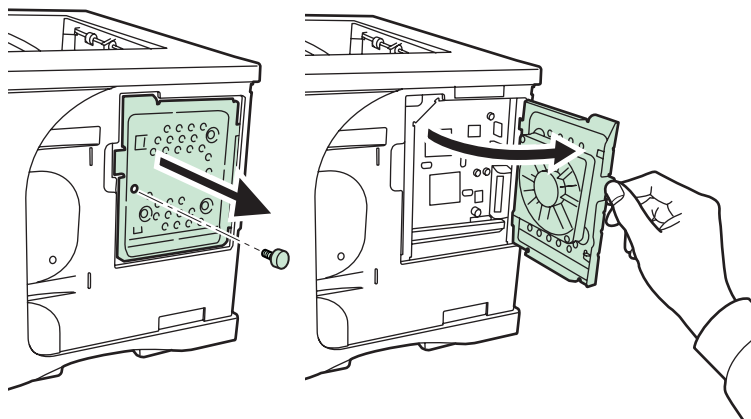

- 4** Push out the clamps on both ends of the memory socket.

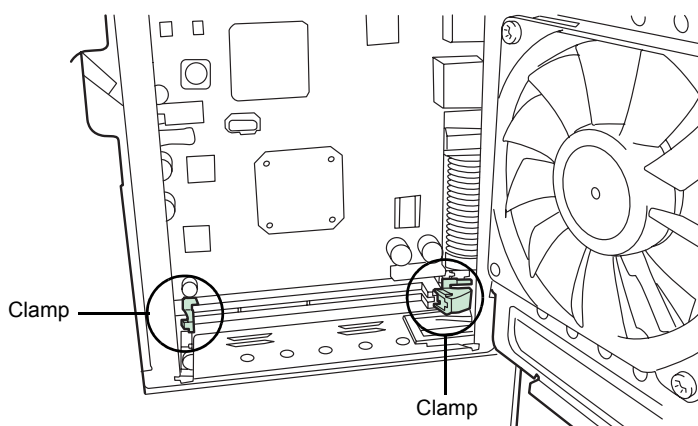

- 5** Remove the memory module from its package. Aligning the cutouts of the memory module with the matching keys of the socket, carefully plug the memory module into the memory socket until it clicks in place.

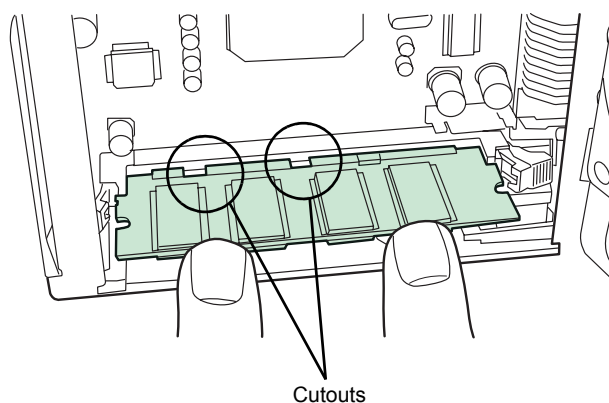

- 6** Push the two socket clamps to secure the memory module.

- 7** After you finish installing the memory module, close the right cover.

### **Removing a Memory Module**

To remove a memory module, open the right cover and inner cover, then carefully push out the two socket clamps. Ease the memory module out of the socket to remove.

### **Testing the expanded memory**

To verify that the memory module is working properly, test it by printing a status page (refer to *Printing a Status Page on page 2-15*).

## General Description

### Microdrive (Hard Disk)/CompactFlash (Memory) Card

Insert the Microdrive/CompactFlash card into its slot on the printer. If a Microdrive/CompactFlash card is installed in the printer, received data can be rasterized and stored on this Microdrive/CompactFlash card. This enables high-speed printing of multiple copies using an electric sort function. Also, you can use the e-MPS functions. For details, refer to *e-MPS on page 2-19*.

For details of available Microdrive/CompactFlash card, refer to your dealer.

- 1** Turn off the printer and disconnect the power cord and printer cable.
- 2** Open the option interface slot cover.

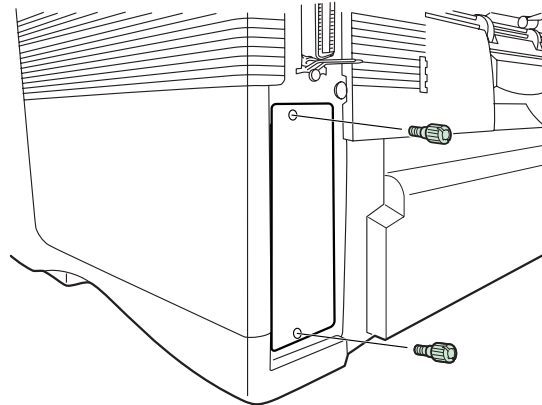

- 3** Install the Microdrive/CompactFlash card into the slot.

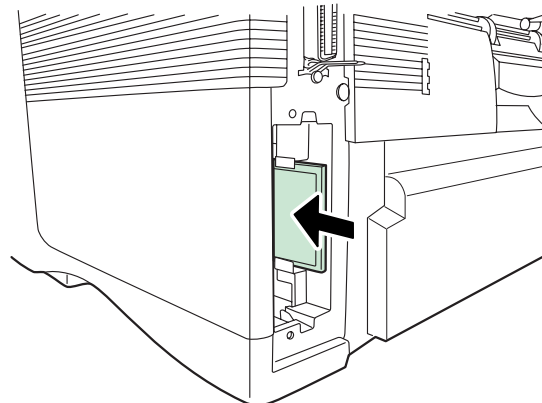

- 4** Close the option interface slot cover.

### PF-310 Paper Feeder

Holds approximately 500 sheets of A5 to A4/Letter and Legal size paper. Up to three paper feeders can be attached to the bottom of the printer.

The PF-310 paper feeder allows you to add three (FS-2000D: one) more paper cassettes to the bottom of the printer for continuous feeding of a large volume of paper. Each paper cassette can hold up to approximately 500 sheets of ISO A4, ISO A5, JIS B5, letter, and legal size (80g/m<sup>2</sup>) paper. This feeder is attached at the bottom of the printer as shown below.

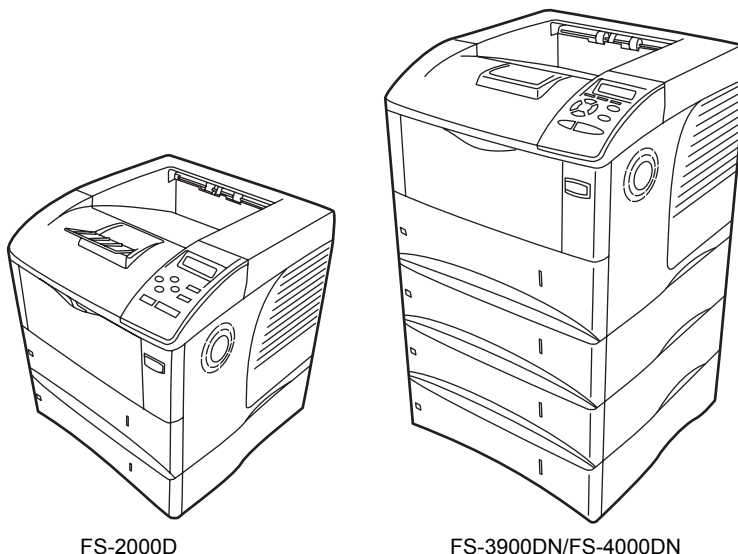

### PT-310 Faceup Output Tray (for FS-3900DN/FS-4000DN)

Use the faceup output tray when you wish paper to be stacked with the printed side facing up (reverse order).

To install the faceup output tray, perform the following procedures:

- 1 Install the paper stopper according to the size of paper to be used.

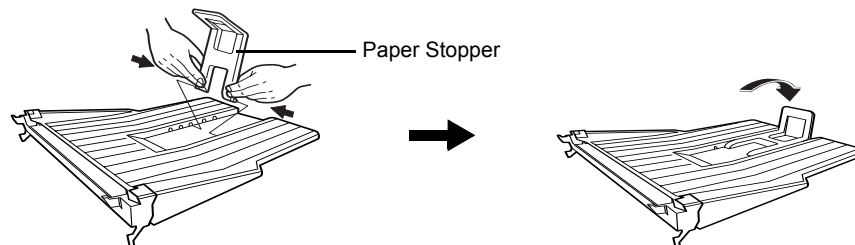
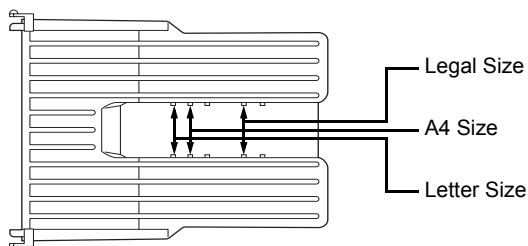

- 2** Install the faceup output tray on the rear of the printer.

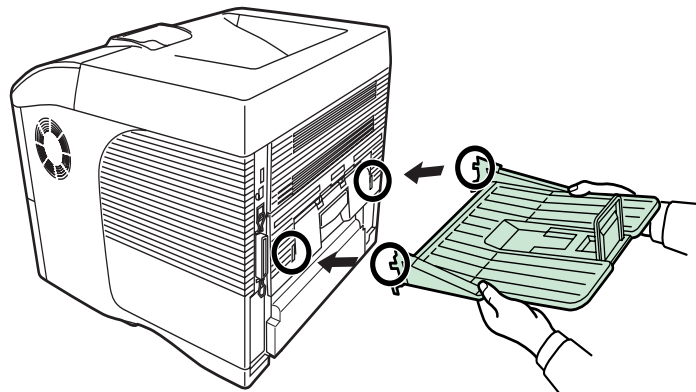

## IB-21E/IB-30 Network Interface Cards

Along with the standard for the network interface on the printer, the network interface card supports TCP/IP, IPX/SPX, NetBEUI and AppleTalk protocols, so that the printer can be used on network environments including Windows, Macintosh, UNIX, NetWare, etc. The network interface card must be installed in the option interface slot that is located at the back of the printer as shown below.

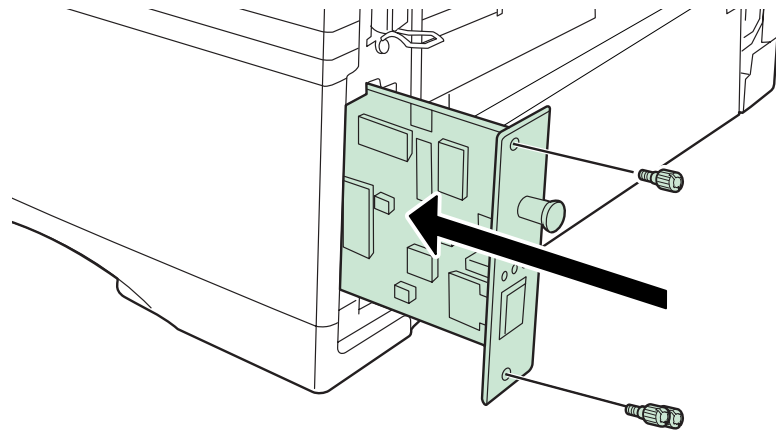

Network interface card	Network connections
IB-21E	10Base-T/100Base-TX
IB-30 (for FS-2000D only)	10Base-T/100Base-TX

## Other Options

### PF-315 Bulk Paper Feeder (for FS-3900DN/FS-4000DN)

Holds approximately 2,000 sheets of 76 to 216 mm × 148 to 305 mm size paper. This bulk paper feeder can be attached to the front of the printer after the MP tray has been removed.

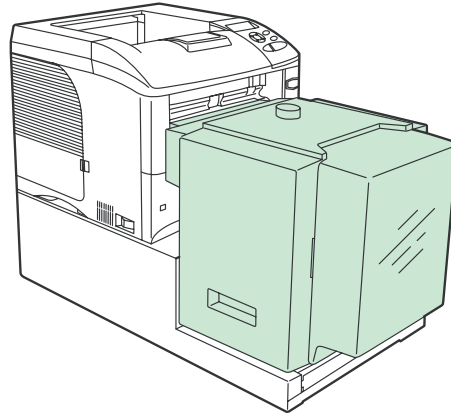

### EF-310 Envelope Feeder (for FS-3900DN/FS-4000DN)

Holds more envelopes at a time than the MP tray. This envelope feeder can be attached to the front of the printer after the MP tray has been removed.

### USB Flash Memory

See your dealer for purchasing information of this optional device that are best suited for use with this printer.



# 4 Computer Interface

This chapter contains explanations on the following topics:

- General Information..... 4-2
- Parallel Interface ..... 4-3
- USB Interface ..... 4-5
- Serial Interface (Option) ..... 4-6
- RS-232C Protocol ..... 4-7
- RS-232C Cable Connection ..... 4-10

## General Information

This chapter explains the signals used in the printer's parallel, USB, and serial (option) interfaces. It also lists pin assignments, signal functions, timings, connector specifications, and voltage levels.

This chapter explains the following topics:

- Parallel Interface
- USB Interface
- Serial Interface (Option)

## Parallel Interface

### Communication Modes

The printer provides high-speed data transmission on a parallel interface. You can select the parallel interface communication mode from the operation panel. To change communication mode, refer to *Changing Parallel Interface Mode on page 2-30*.

**NOTE:** Use a parallel interface cable that complies with the IEEE 1284 standard.

You can choose from four communication modes:

Communication Mode	Reception	Transmission
Auto (default)	High-speed/ECP	Nibble/ECP
Nibble	High-speed	Nibble
High-speed	High-speed	—
Normal	Normal	—

### Interface Signals

Table shows the connector pins and corresponding input and output signals of the parallel interface. Explanation of each signal is also given in the table.

The description in [ ] indicates signal names in Auto mode and Nibble (high) mode (IEEE 1284-compliant). In Auto and Nibble modes, these signals are bidirectional.

Pin	In or out	Signal	Description
1	In	Strobe <sup>†</sup> [nStrobe]	A negative-going-strobe pulse causes the printer to read and latch the data on the Data 0 [1] to Data 7 [8] signal lines. These eight signals form one byte of data sent from host computer to printer. Data 7 [8] is the most significant bit.
2	In	Data 0 [Data 1]	
3	In	Data 1 [Data 2]	
4	In	Data 2 [Data 3]	
5	In	Data 3 [Data 4]	
6	In	Data 4 [Data 5]	
7	In	Data 5 [Data 6]	
8	In	Data 6 [Data 7]	
9	In	Data 7 [Data 8]	

Pin	In or out	Signal	Description
10	Out	Acknowledge <sup>†</sup> [nAck]	This negative-going pulse acknowledges the previous character received.
11	Out	Busy [Busy]	When this signal is high, the printer is busy. When it is low, the printer is able to receive more data.
12	Out	Paper Empty [PError]	This signal goes high when the printer runs out of paper. <sup>††</sup>
13	Out	Online (Select) [Select]	This signal goes high when the printer is online and low when the printer is offline. The signal goes low when you press <b>[GO]</b> to make the printer go off line. <sup>††</sup>
14	In	— [nAutoFd]	Ignored
15	—	—	Not used
16	—	0 V DC	
17	—	Chassis Ground	
18	—	+5 V DC	This pin is used for the printer's +5 V DC power supply (+5±0.5 V, 400 mA maximum, with fuse)
19	—	Ground return	
20	—	Ground return	
21	—	Ground return	
22	—	Ground return	
23	—	Ground return	
24	—	Ground return	
25	—	Ground return	
26	—	Ground return	
27	—	Ground return	
28	—	Ground return	
29	—	Ground return	
30	—	Ground return	
31	In	— [nInit]	Ignored
32	Out	Error <sup>†</sup> [nFault]	When the high-speed parallel line control is on, this line returns an error status. <sup>††</sup>
33	—	—	Not used
34	—	—	Not used
35	Out	Power Ready	This signal goes high when the printer is powered on.
36	In	Select In [nSelect In]	When this line is high, IEEE1284 mode is enabled.

†. Indicates signals that are low active.

††. The Paper Empty, Online, and Error signals work only after you have enabled them using the O2 parameter of the FRPO command.

## USB Interface

This printer supports the Hi-Speed USB. USB (Universal Serial Bus) interface specifications and interface signals are as follows.

### Specifications

#### Basic specification

Complies with the Hi-Speed USB.

#### Connectors

Printer: B-type receptacle (female) with upstream port

Cable: B-type plug (male)

#### Cable

Use a shielded cable that complies with USB 2.0 (Hi-Speed USB) and not longer than 5 meters (16 feet).

#### Transfer Mode

High speed (480 Mbps maximum)

#### Power Control

Self-power device

## Interface Signals

### USB Connector Pin Assignment

Pin	Signal	Description
1	Vbus	Power supply (+5 V)
2	D-	Data transmission
3	D+	Data transmission
4	GND	Signal ground
Shell	—	Shield

## Serial Interface (Option)

Installing the optional serial interface board kit (IB-11) in the printer enables connection to a computer with an RS-232C standard serial interface.

### Interface Signals

The table below shows the pins and corresponding input and output signals of the RS-232C interface connector.

Pin	In or out	Signal	Description
1	—	FG	Frame Ground. This pin is connected directly to the printer frame.
2	Out	TXD	Transmit Data. This pin is used to output asynchronous data sent from the printer to the computer. This signal is often used in handshaking.
3	In	RXD	Receive Data. This pin is used to input serial asynchronous data sent from the computer to the printer.
4	Out	RTS	Request To Send. This output is always high (above 3 volts).
5	In	CTS	Clear To Send. Not used.
6	In	DSR	Data Set Ready. Not used.
7	—	SG	Signal Ground. This pin is used to establish a common reference level for the voltages of all signals other than Frame Ground.
20	Out	DTR	Data Terminal Ready. This pin is used to notify the status of the printer buffer (i.e., nearly full or nearly empty) when handshaking is used. The pin goes high (above 3 volts) when the buffer is able to accept more data.

### Interface voltage levels

The voltage levels of the interface signals conform to EIA RS-232C specifications. The voltage level of SPACE is 3 to 15 volts. The voltage level of MARK is -3 to -15 volts. Voltages between -3 and 3 volts are undefined.

## RS-232C Protocol

### Parameters of the RS-232C Protocol

A protocol is a set of rules followed by various devices to send or receive data. The parameters of the RS-232C protocol are stored in the battery-powered memory of the printer. You can verify these parameters on the status printout as marked by the following identifications:

- H1: Baud rate
- H2: Number of data bits
- H3: Number of stop bits
- H4: Parity
- H5: Protocol logic
- H6: Buffer-nearly-full threshold
- H7: Buffer nearly-empty threshold
- H8: Received data buffer size

The parameters can be changed from the printer operation panel. To change the value for the serial interface parameters, refer to *Changing Serial Interface Parameters* on page 2-31.

This following section outlines the parameters and their values you can select on the operation panel:

#### H1: Baud rate

Parameter value	Baud rate
12	1200
24	2400
48	4800
96	9600
19	19200
38	38400
57	57600
11	115200

The factory setting is 96 (9600 baud).

#### H2: Number of data bits

7 or 8. The factory setting is 8.

#### H3: Number of stop bits

1 or 2. The factory setting is 1.

**H4: Parity**

Parameter value	Baud rate
0	None
1	Odd
2	Even
3	Ignored

The factory setting is 0 (none).

**H5: Protocol logic**

Parameter value	Baud rate
0	Combination of DTR (positive logic) and XON/XOFF
1	DTR (positive logic)
2	DTR (negative logic)
3	XON/XOFF
4	ETX/ACK

The factory setting is 0.

**H6: Buffer nearly-full threshold**

A percentage value from 0 to 99. The factory setting is 90.

**H7: Buffer nearly-empty threshold**

A percentage value from 0 to 99. The factory setting is 70. The factory settings of the buffer nearly-full and nearly-empty thresholds (H6 and H7) are subject to change without notice.

The difference between the nearly-full and nearly-empty thresholds allows the computer to send a fairly large amount of data in a continuous stream.

**H8: Received data buffer size**

The input buffer size is specified in increments which vary depending on the S5 parameter. When S5 is 0, the increment is 10KB. When S5 is 1, the increment is 100KB. When S5 is 2, the increment is 1024KB. The factory setting is 12 (1200KB, S5=1).

## PRESCRIBE FRPO D0 Command

The PRESCRIBE FRPO D0 command is provided to allow manipulating XON/XOFF when an error has occurred on the serial interface. The following table summarizes the error status corresponding to different D0 values.

Timing of XON transfer to host while Ready or Waiting	Serial interface error	
	error not handled	error handled
XON sent every 3-5 seconds	D0=0 (default)	D0=1
XON not sent	D0=10	D0=11

## RS-232C Cable Connection

### Connecting the Printer to the Computer

Make sure that both computer and printer are powered off.

- 1** Discharge static electricity from your body by touching a metal object such as a doorknob.
- 2** Plug the end (printer side) of the RS-232C cable into the printer's serial interface connector and screw it on securely.
- 3** Plug the other end of the cable into the computer's serial interface connector.
- 4** Power on the printer.
- 5** The printer's parameters are set at the factory as follows:
  - Baud rate = 9600 bps, data bits (character length) = 8, stop bits = 1, parity = none
  - The two RS-232C protocols are XON/XOFF and DTR. The printer executes both of these protocols simultaneously, using positive logic for DTR.

If you are not sure about the printer's current parameter settings, reset them to the values shown above (i.e., baud rate = 9600 bps, etc.). You can perform parameter settings from the operation panel. Refer to *Changing Serial Interface Parameters on page 2-31*.

- 6** On the computer, set the same parameters as that of the printer. Most computers allow you to do this by DIP switch settings that should be made before power is turned on.

#### With Windows XP, make settings as follows:

- 1** Click on the **Start** button in the Windows XP task bar and align the cursor with **Settings**, then click on **Control Panel** from among the items displayed.
- 2** The **Control Panel** window opens. Double click on **System**.

- 3** **System Properties** window opens. Click on the **Hardware** tab, then click on the **Device Manager** button, and double click on **Ports (COM & LPT)**.

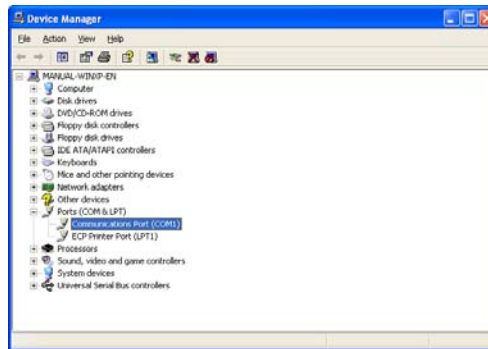

- 4** Double click on **Communications Port**.

- 5** The **Communications Port Properties** dialog is displayed for the selected COM port. Click on the **Port Settings** tab and set the port properties.

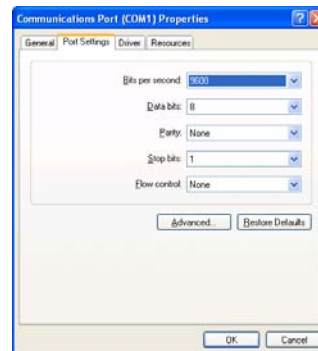

- 6** After setting the properties, click the **OK** button.

**With Windows 95/98/Me, make settings as follows:**

- 1** Click on the **Start** button in the Windows 95/98/Me task bar and align the cursor with **Settings**, then click on **Control Panel** from among the items displayed.
- 2** The **Control Panel** window opens. Double click on **System**.

- 3 **System Properties** window opens. Click on the **Device Manager** tab, then double click on **Ports (COM & LPT)**.

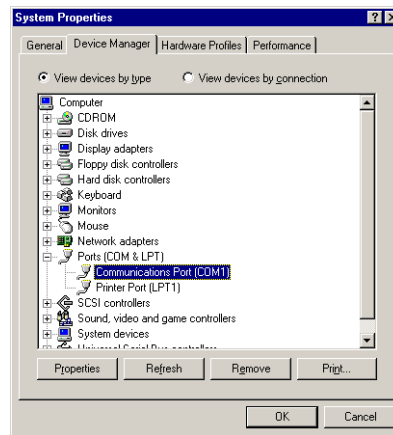

- 4 Double click on **Communications Port**.
- 5 The **Communications Port Properties** dialog is displayed for the selected COM port. Click on the **Port Settings** tab and set the port properties.

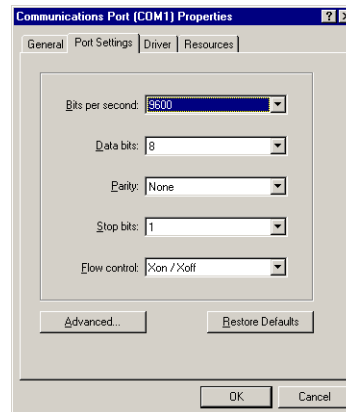

- 6 After setting the properties, click the **OK** button.

The software settings made using the above procedures are temporary. On most computers, permanent settings must be made with DIP switches.

# Glossary

<b>Additional memory</b>	An additional memory (optional) is used for increasing the memory capacity of this machine. For DIMM that can be used in this machine, contact your service technician.
<b>AppleTalk</b>	AppleTalk offers file sharing and printer sharing and it also enables you to utilize application software that is on another computer on the same AppleTalk network.
<b>Default Gateway</b>	This indicates the device, such as a computer or router, that serves as the entrance/exit (gateway) for accessing computers outside of the network that you are on. When no specific gateway is designated for a destination IP address, data is sent to the host that is designated as the Default Gateway.
<b>DHCP (Dynamic Host Configuration Protocol)</b>	This is a protocol that automatically resolves the IP address, Subnet Mask and Gateway address on a TCP/IP network. Use of DHCP minimizes the load of network administration, especially on network environments with a large number of client computers where it is not specifically necessary to assign a separate IP address to each client, including printers.
<b>dpi (dots per inch)</b>	This indicates the number of dots printed per inch (25.4mm) as a unit for expressing resolution.
<b>EcoPrint</b>	This is a printing mode that reduces toner consumption. Pages printed in the EcoPrint mode are lighter than pages printed in the normal mode.
<b>Emulation</b>	This refers to emulation of other manufacturers' printers. The printer emulates operation of the following printers: PCL6, KPDL, Line Printer, IBM Proprinter, DIABLO 630, and EPSON LQ-850.
<b>Form Feed Timeout</b>	While data is being sent to a printer, some pauses may occur. At this time, the printer waits for the next data without making a page break. Form feed timeout is a function to wait only a preset amount of time before it executes an automatic page break. After the waiting period begins, once the designated amount of time is exceeded, the printer will automatically process the currently received data and print it out. If the machine has received no print data for the last page, the printer ends processing of that job without outputting paper.
<b>IEEE1284</b>	This is a standard used when connecting a printer to a computer, and was established by the Institute of Electrical and Electronic Engineers in 1994.
<b>IP Address (Internet Protocol Address)</b>	The Internet Protocol address is a unique number that represents a specific computer in a network. The format of an IP Address is four numbers separated by dots, e.g. 192.168.110.171. Each number should be a decimal between 0 and 255.

<b>KPDL</b>	KPDL is Kyocera's implementation of the PostScript page description language Level3.
<b>MP tray</b>	This tray is used instead of the cassette when printing on envelopes, postcards, transparency sheets, and labels.
<b>NetBEUI (NetBIOS Extended User Interface)</b>	An enhanced version of the NetBIOS protocol, it enables the utilization of more advanced functions on small-scale networks than do other protocols such as TCP/IP, etc.
<b>Outline font</b>	With outline fonts, character outlines are represented with numerical expressions and fonts can be enlarged or reduced in different ways by changing the numeric values of those expressions. Printing remains clear even if you enlarge fonts, since the characters are defined with outlines represented with numerical expressions. You can specify the font size in steps of 0.25 points up to 999.75 points.
<b>Parallel interface</b>	With this interface, data transfer between the printer and the computer takes place in 8-bit chunks. The printer can perform IEEE1284 compatible bi-directional communications.
<b>PostScript</b>	This is a page description language developed by Adobe Systems, Inc. It enables flexible font functions and highly-functional graphics, allowing higher quality printing.
<b>PPM (prints per minute)</b>	This indicates the number of printouts made in one minute.
<b>Printer driver</b>	The printer driver makes it possible for you to print data created using application software. The printer driver for the printer is contained on the CD-ROM supplied with the printer. Install the printer driver on the computer connected to the printer.
<b>Sleep mode</b>	This mode is provided to save power. It is activated when the machine is not used for a preset period of time. In this mode, power is reduced to the minimum. The default time period is 15 minutes. The default setting can be changed.
<b>Status page</b>	This lists machine conditions, such as the machine's memory, the total number of prints and paper source settings. You can print the status page from the operation panel.
<b>Subnet Mask</b>	This is a 32-bit numerical value that defines which bits of the IP address specify the network address and which specify the host address.
<b>TCP/IP (Transmission Control Protocol/Internet Protocol)</b>	TCP/IP is a suite of protocols designed to define the way computers and other devices communicate with each other over a network.
<b>USB (Universal Serial Bus)</b>	An interface standard for low to middle speed serial interfaces. This printer supports Hi-Speed USB. The maximum transfer rate is 480 Mbps and the maximum cable length is 5 meters (16 feet).

# Index

## A

---

Additional memory [Glossary-1](#)

Audible alarm  
how to set [2-83](#)

Auto-continue  
changing recovery time [2-85](#)  
how to set [2-84](#)

## C

---

Carriage return  
how to select [2-48](#)

Color paper [1-10](#)

CompactFlash card  
inserting in the slot [3-6](#)

Counters  
reading the life counters [2-77](#)  
reading the total printed pages [2-77](#)

## D

---

Data dump  
receiving data for dumping [2-81](#)

Duplex printing  
binding modes [2-71](#)  
description [2-71](#)

## E

---

EcoPrint mode  
how to select [2-51](#)

e-MPS  
changing configuration [2-26](#)  
general information [2-19](#)  
how to change hard disk spaces [2-26](#)  
printing a list of code jobs [2-24](#)

Emulation  
appearing on the status page [2-17](#)  
KPD, printing errors [2-38](#)  
setting the default using the operator panel [2-38](#)

Envelope [1-10](#)

Error log  
on the status page [2-17](#)

## F

---

Faceup output tray [3-7](#)

Font  
adjusting character pitch for fixed fonts [2-42](#)  
changing the default size [2-41](#)  
printing lists of fonts [2-43](#)  
sample of the font list [2-44](#)  
selecting regular or dark Courier/Letter Gothic [2-40](#)  
setting the default using the operator panel [2-39](#)

Formfeed  
changing timeout time [2-79](#)

## H

---

Handling [1-1](#)

Hard disk  
deleting data [2-57](#)  
formatting [2-58](#)  
writing data [2-56](#)

## I

---

Indicators  
Interface [2-5](#)  
Paper Size [2-5](#)  
Paper Type [2-6](#)  
Ready, Data, Attention [2-6](#)

## J

---

Job retention  
functions tabled [2-19](#)  
private job, how to use [2-22](#)  
proof-and-hold, how to use [2-21](#)  
quick copy, how to use [2-20](#)

Job storage

functions [2-20](#)

## K

---

### Keys

- basic operation [2-8](#)
- Cancel [2-8](#)
- Cursor keys [2-9](#)
- Go [2-8](#)
- Menu [2-8](#)
- OK [2-9](#)

### KIR mode

- how to select [2-50](#)

## L

---

### Label [1-8](#)

### Linefeed

- how to select [2-47](#)

## M

---

### Memory

- expanding memory [3-3](#)
- installing memory modules [3-3](#)
- on the status page [2-17](#)

### Memory card

- deleting data [2-57](#)
- formatting [2-58](#)
- writing data [2-56](#)

### Menu map

- how to print [2-15](#)
- sample [2-13](#)

### Menu selection system

- road map [2-11](#)

### Message display

- changing the language [2-78](#)
- indicators included [2-5](#)
- status information [2-4](#)

### Microdrive

- inserting in the slot [3-6](#)

### MP tray

- defined [Glossary-2](#)
- first mode, cassette mode [2-64](#)
- setting the paper size [2-65](#)
- setting the paper type [2-66](#)

## N

---

### Network interface

- a sample of the network status page [2-37](#)
- interface cards, diagrammed [3-8](#)
- printing a network status page [2-36](#)
- protocols and parameters [2-33](#)
- resolving the IP address [2-34](#)

### Number of copies

- how to select [2-45](#)

## O

---

### Operator panel

- configuring the printer defaults [2-38](#)
- diagram [2-3](#)
- function [2-3](#)

### Options [3-2](#)

### Orientation

- how to select [2-45](#)

### Outline font [Glossary-2](#)

### Output device

- how to select [2-73](#)

### Override A4/Letter

- description [2-73](#)

## P

---

### Page protect mode

- how to select [2-46](#)

### Paper

- minimum and maximum sizes [1-3](#)
- paper sizes tabled, as Paper Size indicator [2-5](#)
- paper types, as Paper Type indicator [2-6](#)

### Paper cassette

- selecting the paper feed source [2-70](#)
- setting paper size [2-67](#)
- setting paper type [2-69](#)

### Paper feeder

- diagrammed [3-6](#)

### Paper Input

- Specifications [1-2](#)

### Paper Specifications [1-2](#)

### Paper type

- creating custom [2-73](#)
- how to create custom paper types [2-74](#)
- resetting the custom paper type [2-76](#)

### Parallel interface

- changing parallel interface mode [2-30](#)
- signals and definitions [4-3](#)
- understanding the modes [4-3](#)

#### Partition

- a sample of the partition list [2-60](#)
- printing a list of [2-59](#)

#### Postcard [1-9](#)

#### Preprinted paper [1-10](#)

#### Print Density

- how to select [2-52](#)

#### Print quality

- Gloss mode [2-51](#), [2-52](#)

#### Print Resolution

- how to select [2-52](#)

## R

---

#### RAM disk

- setup [2-54](#)

#### Recycled paper [1-11](#)

#### Reset

- resetting the printer [2-82](#)

#### Resource protection

- description [2-82](#)

## S

---

#### Serial interface

- changing parameters [2-31](#)
- computer interface [4-10](#)
- protocol, RS-232C [4-7](#)
- signals and definitions [4-6](#)

#### Setting the Timer [2-79](#)

#### Sleep mode [Glossary-2](#)

#### Sleep timer

- setting the timer [2-79](#)
- setting timeout time [2-80](#)

#### Special paper [1-7](#)

#### Specifications

- Paper [1-2](#)

#### Status page

- how to print [2-15](#)
- understanding [2-16](#)

#### Storage device

- reading fonts from [2-54](#)
- reading/writing [2-55](#)
- writing data [2-56](#)

## T

---

#### Thick paper [1-10](#)

#### Transparency [1-8](#)

## U

---

#### USB flash memory [2-63](#)

#### USB interface

- pin assignment [4-5](#)
- specifications [4-5](#)

## V

---

#### Virtual mailbox

- functions [2-20](#)
- how to change the maximum space [2-29](#)
- printing a list of mailboxes [2-24](#)
- retrieving jobs from [2-24](#)



**QUALITY  
CERTIFICATE**

This machine has passed  
all quality controls and  
final inspection.

## KYOCERA MITA AMERICA, INC.

### **Headquarters:**

225 Sand Road,  
Fairfield, New Jersey 07004-0008  
TEL : (973) 808-8444  
FAX : (973) 882-6000

### **New York Branch:**

1410 Broadway 23rd floor  
New York, NY 10018  
TEL : (917) 286-5400  
FAX : (917) 286-5402

### **Northeastern Region:**

225 Sand Road,  
Fairfield, New Jersey 07004-0008  
TEL : (973) 808-8444  
FAX : (973) 882-4401

### **Midwestern Region:**

201 Hansen Court Suite 119  
Wood Dale, Illinois 60191  
TEL : (630) 238-9982  
FAX : (630) 238-9487

### **Western Region:**

14101 Alton Parkway,  
Irvine, California 92618-7006  
TEL : (949) 457-9000  
FAX : (949) 457-9119

### **Southeastern Region:**

1500 Oakbrook Drive,  
Norcross, Georgia 30093  
TEL : (770) 729-9786  
FAX : (770) 729-9873

### **Southwestern Region:**

2825 West Story Road,  
Irving, Texas 75038-5299  
TEL : (972) 550-8987  
FAX : (972) 252-9786

### **National Operation Center & National Training Center:**

2825 West Story Road,  
Irving, Texas 75038-5299  
TEL : (972) 659-0055  
FAX : (972) 570-5816

### **Latin America Division:**

8240 N.W. 52nd. Terrace Dawson Building,  
Suite 108 Miami, Florida 33166  
TEL : (305) 421-6640  
FAX : (305) 421-6666

## KYOCERA MITA CANADA, LTD.

6120 Kestrel Road, Mississauga,  
Ontario L5T 1S8, Canada  
TEL : (905) 670-4425  
FAX : (905) 670-8116

## KYOCERA MITA MEXICO, S.A. DE C.V.

Av. 16 de Septiembre #407  
Col. Santa Inés,  
Azcapotzalco México,  
D.F. 02130, México  
TEL : (55) 5383-2741  
FAX : (55) 5383-7804

## KYOCERA MITA EUROPE B.V.

Hoeksteen 40, 2132 MS Hoofddorp,  
The Netherlands  
Phone: +31.20.654.0000  
Home page: <http://www.kyoceramita-europe.com>  
Email: [info@kyoceramita-europe.com](mailto:info@kyoceramita-europe.com)

KYOCERA MITA NEDERLAND B.V.  
Beechavenue 25, 1119RA Schiphol-Rijk  
The Netherlands  
Phone: +31.20.58.77.200

KYOCERA MITA (UK) LTD  
8 Beacontree Plaza  
Gillette Way Reading Berks RG2 0BS,  
U.K.  
Phone: +44.1189.311.500

KYOCERA MITA ITALIA S.p.A.  
Via G. Verdi, 89 / 91, 20063 Cernusco s/N  
Milano, Italy  
Phone: +39.02.92179.1

S.A. KYOCERA MITA BELGIUM N.V.  
Sint-Martinusweg 199-201, 1930 Zaventem,  
Belgium  
Phone: +32.2.720.9270

KYOCERA MITA FRANCE S.A.  
Parc Les Algorithmes Saint Aubin  
91194 GIF-SUR-YVETTE,  
France  
Phone: +33.1.6985.2600

KYOCERA MITA ESPAÑA S.A.  
Edificio Kyocera, Avda de Manacor No. 2,  
28290 Las Matas (Madrid),  
Spain  
Phone: +34.91.631.8392

KYOCERA MITA FINLAND OY  
Kirvesmiehenkatu 4, 00880 Helsinki,  
Finland  
Phone: +358.9.4780.5200

KYOCERA MITA (SCHWEIZ)  
Hohlstrasse 614, 8048 Zürich  
Switzerland  
Phone: +41.1.908.4949

KYOCERA MITA DEUTSCHLAND GMBH  
Otto-Hahn-Str. 12 D-40670 Meerbusch,  
Germany  
Phone: +49.2159.918.0

KYOCERA MITA GMBH AUSTRIA  
Eduard-Kittenberger-Gasse 95,  
1230 Wien,  
Austria  
Phone: +43.1.86338.210

KYOCERA MITA SVENSKA AB  
Esbogatan 16B 164 75 Kista,  
Sweden  
Phone: +46.8.546.55000

KYOCERA MITA NORGE  
Postboks 150 Oppsal, NO 0619 Oslo  
Olaf Helsetsvetvei 6, NO 0694 Oslo,  
Norway  
Phone: +47.22.62.73.00

KYOCERA MITA DANMARK A/S  
Ejby Industrivej 1, DK-2600 Glostrup,  
Denmark  
Phone: +45.5687.1100

KYOCERA MITA PORTUGAL LDA.  
Rua do Centro Cultural, 41 (Alvalade) 1700-106 Lisbon,  
Portugal  
Phone: +351.21.842.9100

KYOCERA MITA SOUTH AFRICA (PTY) LTD.  
527 Kyalami Boulevard,  
Kyalami Business Park Midrand,  
South Africa  
Phone: +27.(0)11.540.2600

## KYOCERA MITA AMERICA, INC.

Headquarters:  
225 Sand Road,  
Fairfield, New Jersey 07004-0008,  
U.S.A.  
Phone: (973) 808-8444

KYOCERA MITA AUSTRALIA PTY. LTD.  
Level 3, 6-10 Talavera Road, North Ryde,  
N.S.W. 2113 Australia  
Phone: (02) 9888-9999

KYOCERA MITA NEW ZEALAND LTD.  
1-3 Parkhead Place, Albany  
P.O. Box 302 125 NHPC, Auckland,  
New Zealand  
Phone: (09) 415-4517

KYOCERA MITA (THAILAND) CORP., LTD.  
9/209 Ratchada-Prachachem Road,  
Bang Sue, Bangkok 10800, Thailand  
Phone: (02) 586-0320

KYOCERA MITA SINGAPORE PTE LTD.  
121 Genting Lane, 3rd Level,  
Singapore 349572  
Phone: 67418733

KYOCERA MITA HONG KONG LIMITED  
11/F., Mita Centre,  
552-566, Castle Peak Road,  
Tsuen Wan, New Territories,  
Hong Kong  
Phone: 24297422

KYOCERA MITA TAIWAN Corporation.  
7F-1~2, No.41, Lane 221, Gangchi Rd.  
Neihu District, Taipei, Taiwan, 114. R.O.C.  
Phone: (02) 87511560

## KYOCERA MITA Corporation

2-28, 1-chome, Tamatsukuri, Chuo-ku  
Osaka 540-8585, Japan  
Phone: (06) 6764-3555  
<http://www.kyoceramita.com>

©2007 KYOCERA MITA Corporation

 is a trademark of Kyocera Corporation

