

Installation Environment

Kyocera Recommends selecting the Location for the printer as follows:

1. Room Temperature range: 50 to 90.5°F (10°C to 32.5°C)
2. Humidity Level: 10 to 80%
3. Power:
 - 120 V Specification Model:
A dedicated 120VAC 60Hz 15A outlet
 - 230 V Specification Model:
A dedicated 200-240VAC 50/60Hz 15A outlet

Avoid the following locations when selecting a site for the machine. Adverse environmental conditions may affect the image quality.

- + Avoid locations near a window or with exposure to direct sunlight.
- + Avoid locations with vibrations.
- + Avoid locations with rapid temperature fluctuations.
- + Avoid locations with direct exposure to hot or cold air.
- + Avoid poorly ventilated locations.

recommended installation space

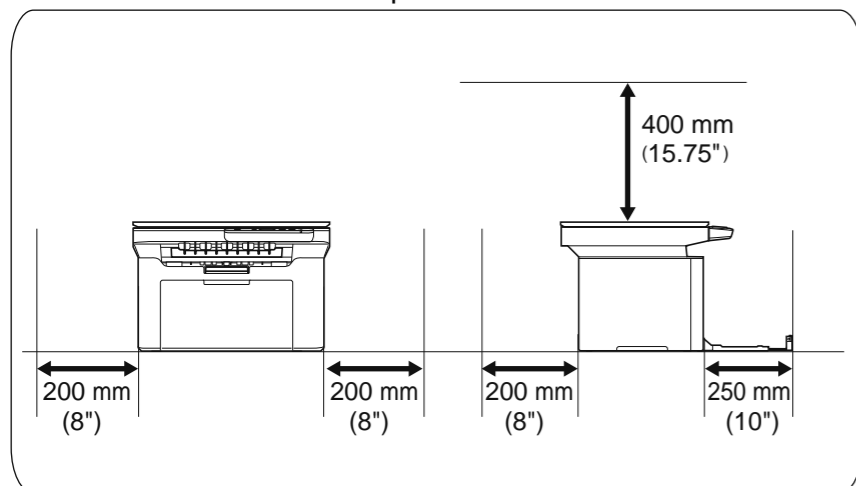

Step1 Setting up the machine

1. Open the Box. Remove the Packing material, cushioning, plastic bag, the power cord, Toner Cartridge, etc.
2. Hold the machine by grasping both sides.

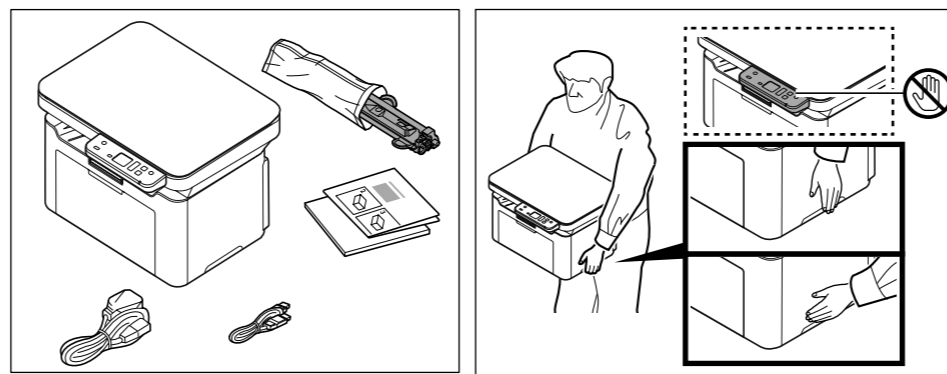

3. Remove the Tape ① as shown. ② Open the Top Cover.

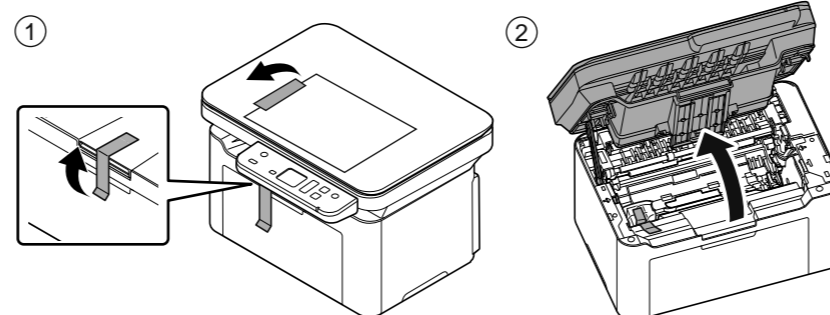

4. Remove the tape and packing ③. Grab the Drum Unit D ④ as shown and lift it from the MFP. ⑤ Place it on a sheet of paper on a flat surface.

Note: The drum unit is sensitive to light. Never expose the drum unit to light for more than five minutes.

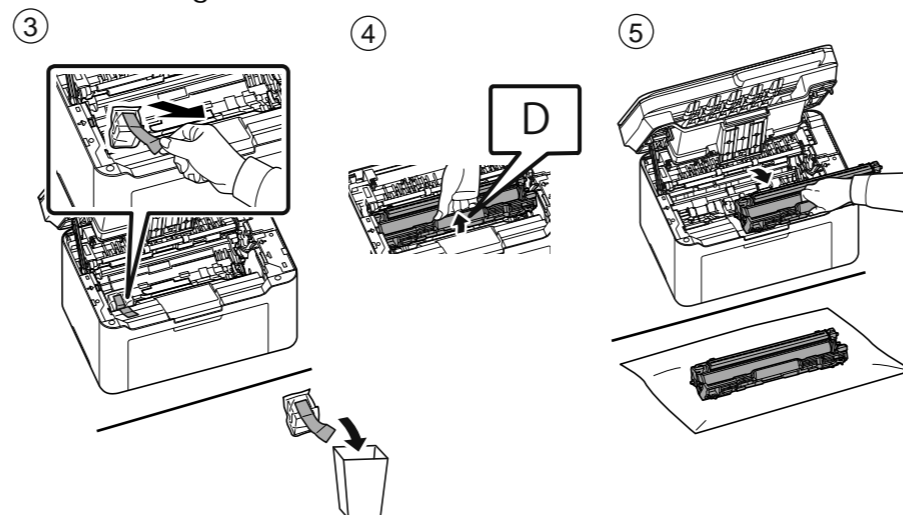

5. Open the front Paper Feeder ⑥ and remove the packing sheet that protects the drum ⑦.

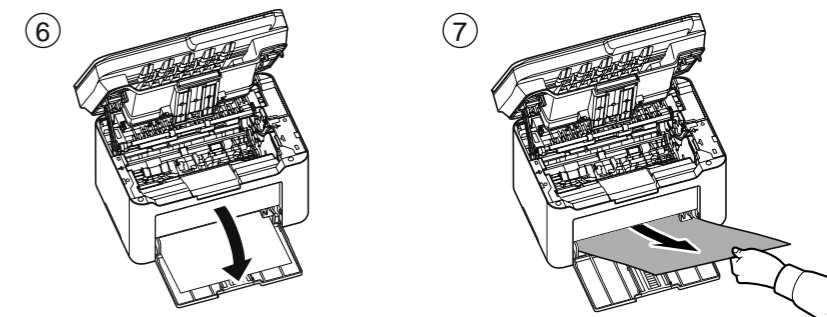

6. Reinstall the Drum Unit D as shown ⑧ and push to lock it in place.

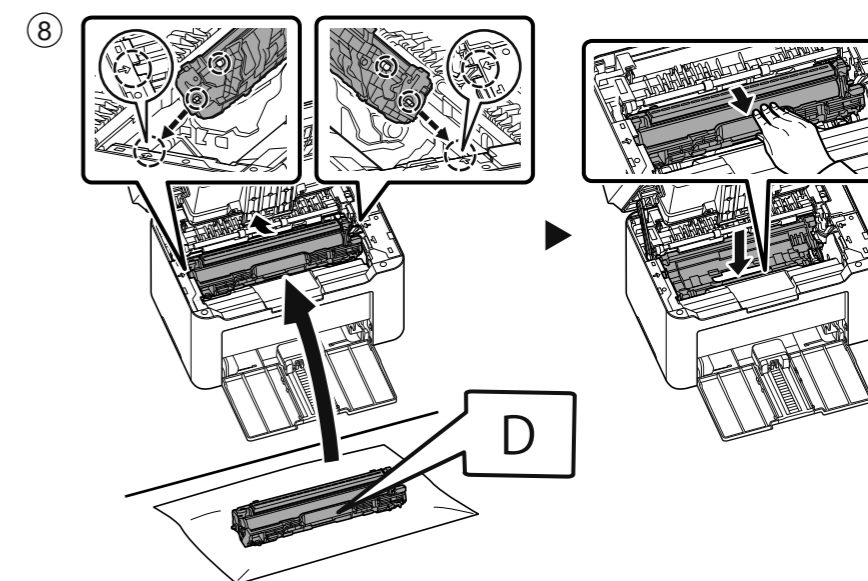

7. Remove the toner cartridge from the bag ⑨, shake it 5 times to loosen toner, ⑩ Unsnap the protective cover on both sides and remove the cover as shown.

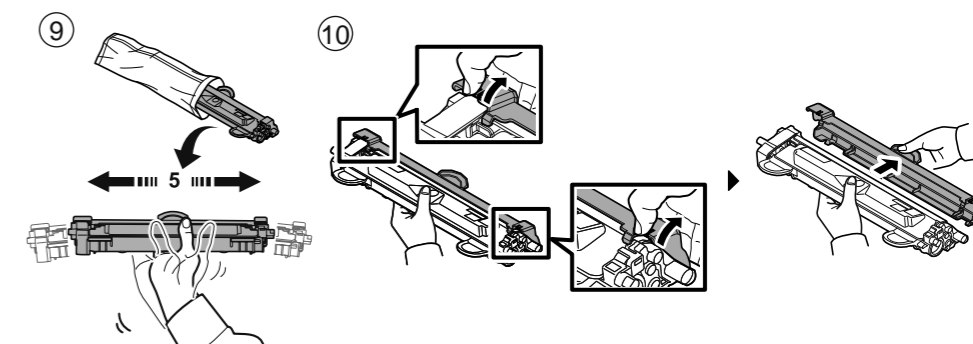

- Set the toner cartridge to its position, aligning the guides at both ends with the slots in the machine. Press the levers on both ends of the Unit until they click in place.

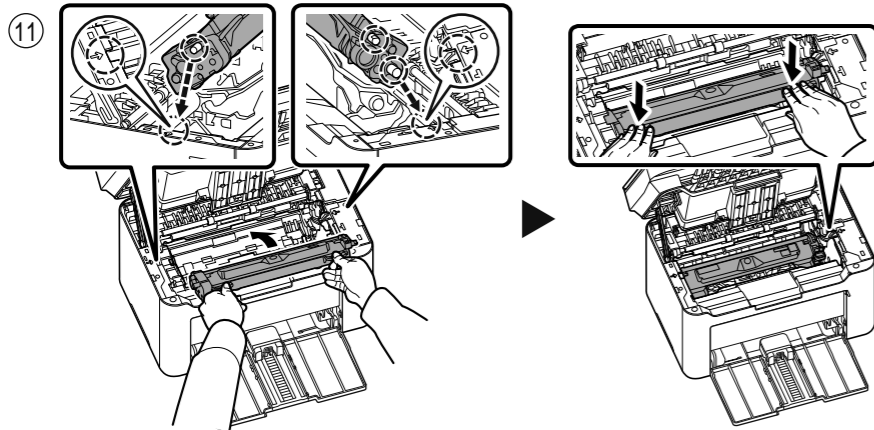

Step2 Loading Paper

- Open the Front Cover.
- When using paper other than A5 (Landscape), remove the stopper from the paper length guide. Keep the removed Stopper for future use.
- Adjust the position of the width guides located on the left and right sides of the cassette.

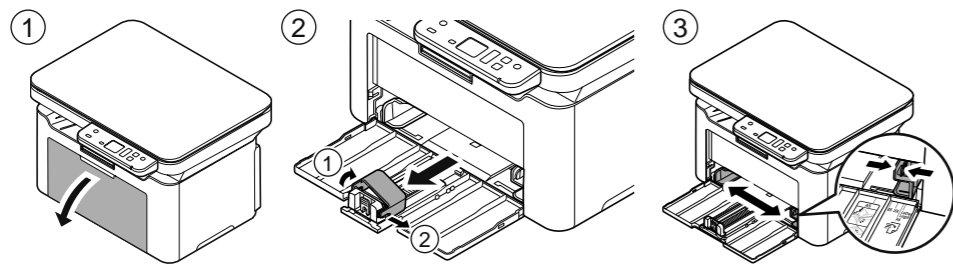

- Adjust the paper length guide to the paper size required.
- After removing paper from the packaging, fan through the sheets to separate them prior to loading.
- Load the paper all the way in the cassette until the paper touches the far inner side. Ensure the side to be printed is facing up and the paper is not folded, curled, or damaged.

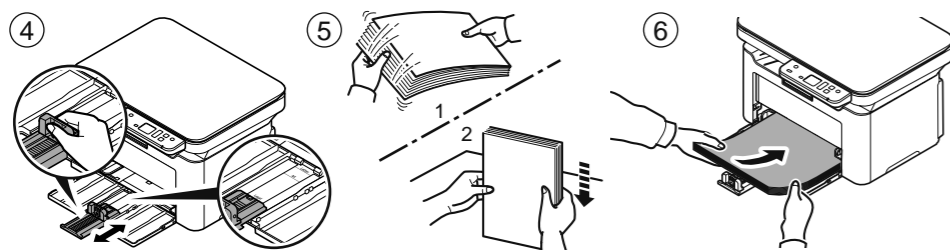

Step3 Power up the machine

- Connect the power cord to the rear of the machine ① and the other end to the power outlet. ② Turn the power switch ON at the front of the printer.

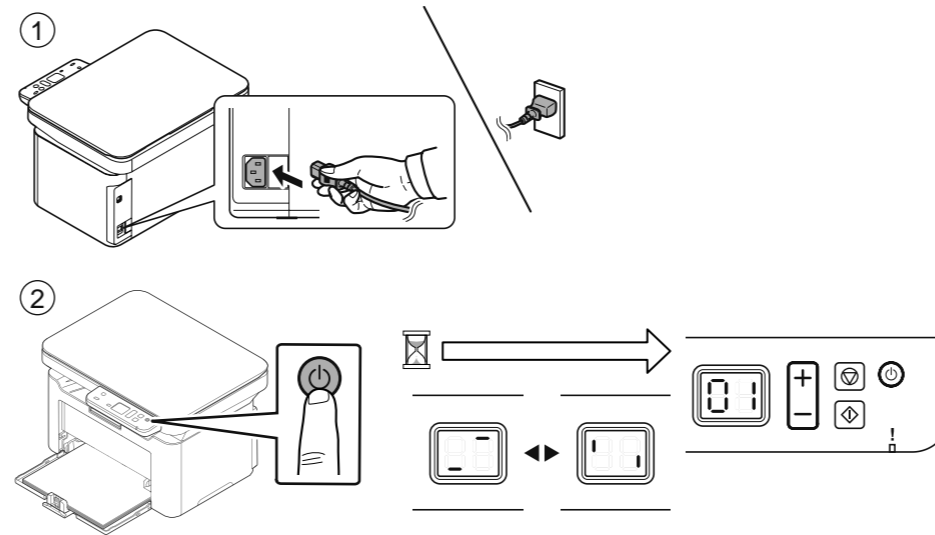

Step4 Print a Status Page

- Print a Status page.
 - Press and hold the Mode Select key for 3 seconds.
 - The attention light will start flashing and status page will be printed.

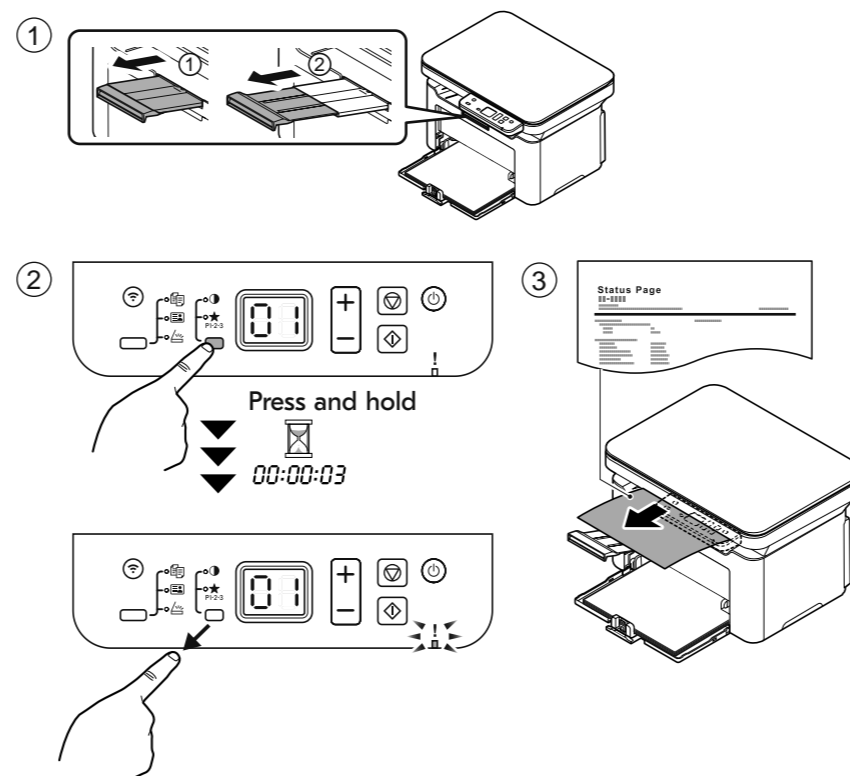

Step5 Installing the software

Access the following URL and select your model and OS.
Download Center: <https://kyocera.info/>

Videos on machine setup, software installation, etc. are also available on this site.

For Windows

Download and run the Web Installer and follow the on-screen instructions to install the driver and software.

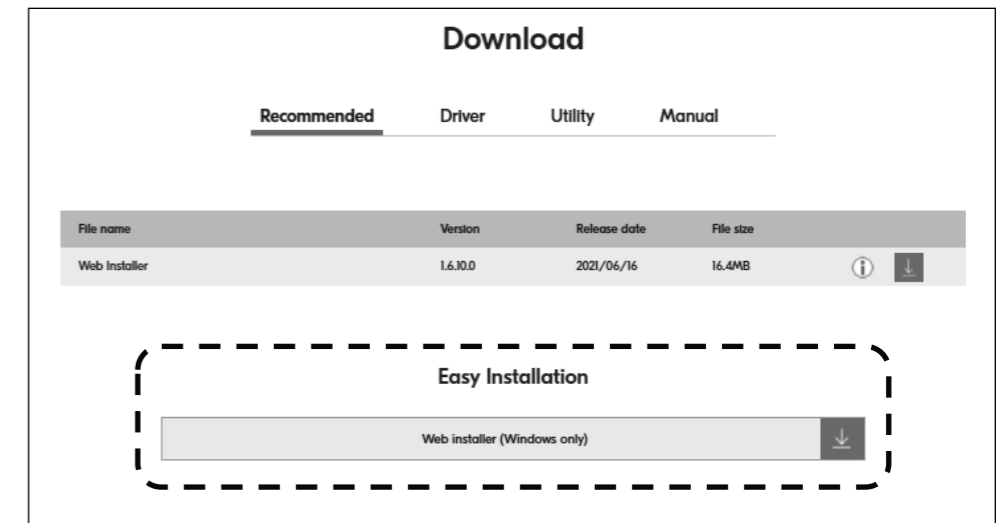

For macOS

Download and run the driver and follow the on-screen instructions to install.

